

A COOKBOOK FOR CAMPERS

EATING OUT

75th Anniversary Project
Provincial Camp Committee
Alberta Council



EATING OUT
A COOKBOOK FOR CAMPERS



75 th Anniversary Project
Provincial Camp Committee
Alberta Council

Editor – Margaret Campbell

ACKNOWLEDGEMENTS

Permission was received from Girl Guides of Canada - Guides du Canada to reprint articles and illustrations from several of their publications.

Alberta Agriculture and the Blue Flame Kitchen, Northwestern Utilities allowed us to reproduce the booklets found in the Appendix.

Carol Paetz contributed the title and designed the lettering for *Eating Out*.

Edna Dach designed the cover and section title pages (First and Second Printing)

Olive Michaud and Phyllis Semaniuk sorted recipes into sections.

Kay Quon and Jean Patterson interested the girls of the 77th Guide Company, Edmonton, in the cookbook. Lita Lapointe, Lise Lavallee, Brenda Bayly, Heather Milne, Michelle Patterson, Abi Patterson, and Janet Quon contributed drawings.

Carol Buss helped with the layout and Jennie Polutranko offered technical advice.

The help and support of the Edmonton Area Camp Advisers was appreciated.

Margaret Campbell

First printing 1985

Second printing 1988

Retypeset and reprinted April 1995

Reprinted 1997

Retypeset and reprinted 1999

INTRODUCTION

This cookbook began with a recipe contest held at the 1984 Camp Advisers' Conference. The entries were numerous, varied, and delicious. The Provincial Camp Committee decided to expand the contest entries into a camp cookbook which would be the Camp Committee's 75th Anniversary Project.

Recipes came in from all over the province: many are old favourites, some provide a new twist on a familiar theme, and a few are exotic. All provide good camp fare.

The recipes were rewritten to conform to a standard format, but the content of each was not altered.

Alberta is well known for its excellent cooks and, judging by the recipes in this book, many of those cooks must be Guiders who camp.

TABLE OF CONTENTS

	Page
Acknowledgements	
Introduction	
Cooking Methods	1
Breakfast	21
Soup, Salad, Sandwiches	27
Bread and Biscuits	37
Dinners, Main Dishes, Vegetables	45
Desserts and Snacks	79
Beverages	99
Light Weight Camping Foods	103
Miscellaneous	110
Appendices	111
A: Food Purchasing Guide for Quantity Service	111
B: Quantity Cooking	119
C: Resource List	129

COOKING METHODS

	Page
Introduction to Cooking Methods	1
Box Oven I	3
Box Oven II	4
Hay Box	5
Dutch Oven	7
Tin Can Cooking	8
How to make a Hobo Oven	9
Charcoal Goes Hiking	11
Individual Barbecue	14
How to make a Reflector Oven	15
Hot Water at Camp	17
Water Heater and Incinerator	19
Improvised Cooking Methods	20

INTRODUCTION TO COOKING METHODS

A variety of cooking methods, which are fuel efficient, time efficient, and interesting, are described in this chapter. Most of these methods are not new ways of doing things but, rather, adaptations of old ways.

There are many resource materials available for the person interested in exploring this subject. There are many camp cook books, some of them excellent and some of them apparently written by people who have camped once and consider themselves experts. The public libraries carry a variety of outdoor cook books so it is not necessary to spend a lot of money to learn more.

Two books which rank high on any list of camp cook books, particularly in the area of cooking techniques, are "Rough It Easy I and II" by Dian Thomas. These and other books are listed in Appendix C.

Have you considered looking through old issues of the *Canadian Guider* for cooking (and gadget) information? These magazines are a marvellous resource of beautifully-illustrated and well-written articles. In this chapter you will find a sampling, including an article from the first issue of the *Canadian Guider*, February 1949.



BOX OVEN I

A foil-covered box can make a very useful and surprisingly efficient addition to your camp kitchen.

BOX SIZE

This depends on the dimensions of the baking dishes to be used inside. An air space of 2 – 3" is needed around the pan to allow heat to circulate. Therefore a 9" square pan would require a 15" square box. The depth of the box should be about 14".

CONSTRUCTION

Choose a sturdy box. Cut the flaps off one end *only*. Flaps on the other end should be loose so they can be opened up. Cover the inside of the box with heavy duty foil, shiny side out, extending the foil to the outside for 2 – 3". Tape the foil down on the outside of the box. Add a second layer of foil in the same way. When applying foil cover the flaps too, cutting the foil between the flaps so the flaps can lie at right angles to the box. Finally cover the outside of the box with foil.

To make a rack for the oven, measure 6" up from the flap end. Make 4 evenly-spaced small holes through the side and 4 corresponding holes on the opposite side. Cut heavy wire or coat hangers to extend half an inch through each side. If this rack is not strong enough, run wires at right angles to them, using the same procedure.

You now have a foil-covered box, open at the top with the flaps that rest on the ground at the bottom. To cover the top of the oven when in use, use roasting film called "Look" or an equivalent product. The roasting film must be tied firmly around the outside of the box. With roasting film, the interior of the oven is visible. If the film is not available, heavy-duty foil may be used. Both film and foil may be re-used.

TO USE THE OVEN

Prepare a charcoal fire in a fire pit or in an area which will allow the box to sit over the coals with the flaps spread out on the ground. The charcoal must be white before the oven is placed over it since there is no air to support combustion once the oven is in place.

Temperature control in the oven is possible using, as a rule of thumb, one briquette for every 480° F of heat desired. Use the same temperature as one would in a regular oven. It is important to use only good quality, fresh briquettes. Cheap briquettes are often poor in quality, burning fast without producing much heat.

When ready to cook, spread briquettes out slightly. They should not be touching the sides of the box oven. Place the box over the coals, spreading flaps out and placing rocks or other weights on the flaps to hold in place and to prevent heat from escaping. Place item to be baked on the rack and cover with film or foil.

Baking will take approximately the same length of time as it would in a regular oven if your estimate of charcoal needed to give a certain temperature is correct. Check the baking regularly.

BOX OVEN II

BOX SIZE

An orange box, the type where the top fits over the bottom, is a practical, sturdy choice.

CONSTRUCTION

Take a box, with the top on, and lay on one of the long sides. Cut around three sides of the box, leaving it attached on the long side on the bottom. This will be the oven "door".

Cover the interior and the "door" with heavy-duty foil, shiny side out. Tape in place on the outside of the box. Two layers of foil make a safer oven.

Find a rack that fits inside the box and support the rack on four cans. Empty fruit or soup cans are excellent. There must be sufficient space between the cans for an aluminum pie plate which will hold the charcoal.

Devise a fastener for the door. A wire loop on the door can be caught on a wire hook on the top of the box. An alternate method is to have the door open up rather than down. In this case the door would have to be held closed with a rock placed against the base of the door.

TO USE THE OVEN

Start charcoal on the aluminum pie plate outside the oven using, as a rule of thumb, one briquette for every 45° F wanted. When the briquettes are white place pie plate and coals in the box oven. Care must be taken when handling the hot coals and plate.

After the oven has been preheated, add items to be baked. Timing is dependent on the amount of heat produced by the charcoal. If the cooking time is long it may be necessary to add more charcoal (already started) to the oven tray.

This oven is useful for cakes and other baked goods.

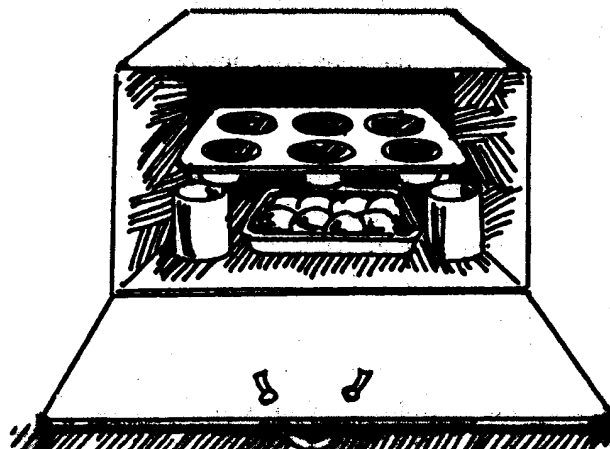

HAY BOX

This is a very old form of a slow cooker or crock pot which has been used extensively in Europe and in the early days of Canada.

There are a variety of ways the box can be constructed. Here we will describe how a box may be made with hay, newspaper, or fibreglass insulation. In all types it is necessary to use a pot with a tight-fitting lid.

These boxes are a real time-saver for the busy camp cook. Breakfast may be prepared the night before and left to cook overnight, eliminating the early morning rush; supper may be prepared after breakfast and left to cook during the day whilst everyone, including the cook, enjoys a variety of other activities.

BOX CONSTRUCTION

Using Hay: Take a large size wood or sturdy cardboard box and line it with several layers of newspaper, pasting layers in place. This will prevent drafts.

Line the box with hay, packing it tightly to a depth of 6". Leave the centre open to receive the cooking pot. It will probably be necessary to pack more hay around the pot to ensure a tight fit. Make a cushion or pad filled with hay to go over the top of the box. The cushion may be made from a piece of sacking or old blanket. The finished bag should be the same size as the top of the box. A flat piece of wood is required to cover the box to prevent heat escaping.

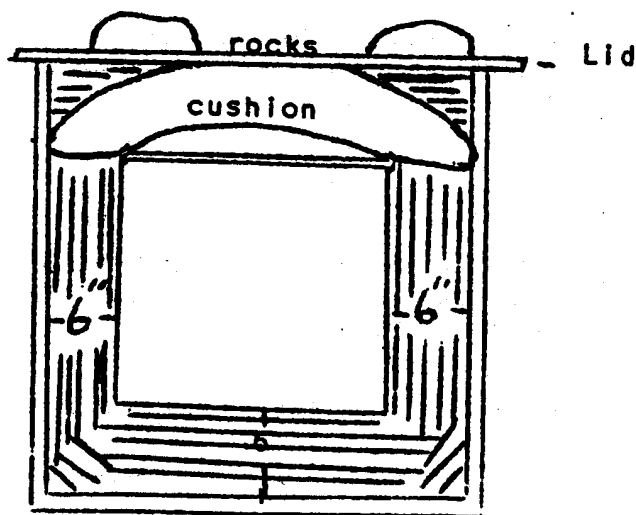

Using Newspaper: Use a sturdy box at least five 5" bigger than the pot on each side. Allow 5" each for the top and bottom of the pot.

Crumple newspaper tightly, one sheet at a time, and place in the box until 5" of well-packed newspaper covers the bottom of the box. Set the pot in the middle of this.

Continue crumpling newspaper and stuff it around the sides of the pot. Stuff until the top of the pot is reached. Lift the pot out and if the newspaper does not stay in place, replace the pot and pack newspaper more firmly. The newspaper, if tightly crumpled and firmly packed, should stay in place when the pot is removed. To cover the pot, use an old pillowcase or sew a pad and stuff with tightly crumpled newspaper. Do not sew the bag shut, as more newspaper will have to be added from time to time. The bag may be closed with safety pins. This pad should fit down over the top of the pot with, if possible, the flaps of the box closed tightly over this.

Using fibreglass: Use a sturdy box large enough to hold the pot and 3" of fibreglass insulation on all sides of the pot.

Cut 2 pieces of fibreglass insulation to fit exactly into the box. Place 1 piece into the bottom, paper side up, and save the other for the top. Cut a strip of fibreglass long enough to fit around all 4 sides of the box and wide enough to reach the top of the pot. Line the box with this; place the paper sides towards the pot. The top piece of insulation fits in on top of the pot.

TO USE THE HAY BOX

Hay, newspaper, and fibreglass are non-conductors of heat so heat escapes very slowly, allowing the food to go on cooking for hours.

Protect the box from wet and cold by putting a blanket or cover over it. A cold cement floor or cold ground will help drain away heat more rapidly. Placing a heavy weight or rocks on top of the box will prevent most animals from gaining access to your precious food.

FOOD PREPARATION

Food should be brought to a boil and cooked for 20 minutes before placing it in the box. Anything containing heat which has been cooking for more than 2 hours should be brought to the boil and simmered for 5 - 10 minutes before serving.

The box is excellent for preparing porridge, stews and chicken (if browned first).

Rice may be prepared by putting rice in cold water and bringing it to a boil. Place in box for 2½ hours. Use 1 cup of rice to 4½ cups of water.

Beverages may be kept hot for hours. For tea, make tea and when ready, take out the bags, and place in the box. It will stay hot and fresh until needed.

DUTCH OVEN

The type of Dutch Oven used for camp cooking is the cast-iron type with a curved lid which can be used with either the concave or convex surface facing up. Some have three legs which are convenient if the Dutch Oven is placed on a bed of coals. There should be a heavy wire bail for lifting the pot on and off the fire. Care of the Dutch Oven is the same as that for a cast iron frying pan.

To use for baking, the lid of the pot is placed concave side up and coals are placed on the lid. When using for soups or stews, place the lid the other way.



TIN CAN COOKING

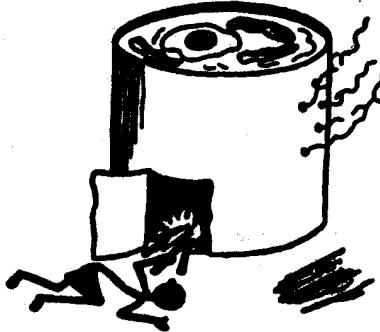

Have you ever tried using a tin can as a fireplace and frying pan combined? It is very simple and easily used. You will need an empty can without the lid (No.10 size is best if you are lucky enough to have one, but a smaller one will do). Turn it upside down and cut a doorway in the side as shown in the sketch. Pierce a few holes near the top on the opposite side to act as a chimney. Collect, for fuel, tinder and kindling sticks only - small twigs are all you will need. Place tinder inside the can and light, feeding it carefully with thin twigs.

Some prefer to light the fire and then place the can over it - either way it is successful. As the top of the can becomes hot, grease it and rub it clean. You can then fry bacon and eggs and make pancakes enough for a good meal.

the "I SAW . . ." CORNER

The Canadian Guider, February 1949

Send your contributions to the "I Saw Corner". Tell us about the interesting things you see in May.

In April I saw the Guides of the Oriole Patrol. They were cooking hamburgers wrapped in paper! They had collected plenty of wood to make a good bed of coals. They had wrapped the thin hamburgers in white wax paper and then wrapped the parcel in *well-wetted*, brown paper (the kind a butcher uses). The Guides pulled their bundles from the coals where they were buried. The outer papers were charred but the hamburgers were well cooked and delicious to eat.



HOW TO MAKE A HOBO OVEN

by K. Robinson
The Canadian Guider, May 1960

Ever make a hobo oven? The ideal thing is to have an oven for each girl, though two can use one.

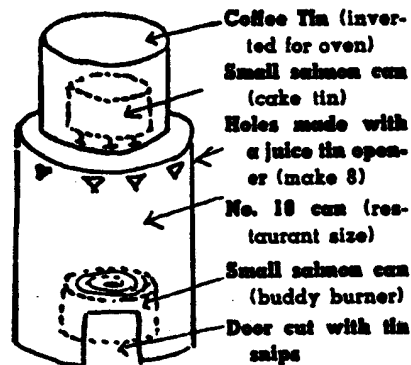

The hobo oven is made of 4 cans of various sizes. Two (2) of these should be the size of salmon cans, small ones; the 3rd a one-pound coffee can; and the other a No. 10 can (this is the regular size that restaurants buy their canned fruit in, a can that has held 5 pounds of powdered milk is about the same size). Take one of the salmon cans and use it to make a buddy burner. Buddy burners are made by taking a long strip of corrugated cardboard, the width and depth of the can, and rolling it, *not too tightly*, until it fills the can. Over this pour melted paraffin wax (or old candle ends) to fill the can, and let it harden. This should be prepared beforehand.

Make holes in the No. 10 can (see illustration). Light the buddy burner and, as soon as the flame spreads evenly over it (the cardboard acts as a wick), place the No. 10 can upside down over it. Put your cake mix in the second salmon can. It is a good idea to line this, or at least the bottom, with paper. Place the cake tin on top of the No. 10 can and invert the coffee can over it as an oven; allow it to cook for 10 to 15 minutes.

A good plan is to put a small flat twist of wire or 3 thumb tacks on top of the No. 10 can and place the cake tin on top of them so that there is air space between the bottom of the "oven" (top of the No. 10 can) and the cake tin. NOTE: small stones make effective spacers between the cake tin and the top of the stove. This helps the cake to cook more evenly.

Be sure, when making this hobo oven, to keep the 4 tins in the proportions given. If you have a larger buddy burner, the cake will burn on the bottom before it is cooked through; if you think you can overcome this by having a larger cake tin you will find, if it is taller, that the cake will rise and stick to the top of the "oven" (coffee can). If it is wider, not sufficient heat can get up around the sides to cook it properly.

When the cake is cooked and you want to put out the burner, just place something flat over it and exclude the air. It will go out in a few moments. *Do not try to blow it out.* A buddy burner this size is more than sufficient to bake a cake. The burner can be refilled with melted wax as often as desired, using the same cardboard each time, unless you let it burn so low that the cardboard burns too low.

This type of oven is excellent unless it is very windy weather; then it is not much use as the oven sections cannot be made sufficiently hot.



CHARCOAL GOES HIKING

by Anne Gloin, Regina, Saskatchewan
The Canadian Guide, February 1965

Have your Guides, Brownies, Rangers, or Cadets faced the challenge of charcoal cooking on hikes? And, for the Brownies and new Guides, charcoal cooking in the backyard is opening the door to new experiences and preparations for things to come.

The girls, of course, have visions of carrying dad's barbecue on their back, since this is the only knowledge of charcoal cookery they have. But please, we can leave it at home.

The simplest way to carry charcoal for hiking purposes is in a dry, waxed, quart-size milk carton or its equivalent. This, filled with charcoal briquettes, is quite adequate for a hiker's dinner. All you do is set a match to the carton, which in turn ignites the charcoal, and your worries about tinder are over. But where do you put this carton of charcoal?

Brownies, Guides, and Rangers using charcoal for the first time enjoy creating their own charcoal hibachis.

A 7" diameter flower pot can be 2/3 filled with sand, soil, or gravel for the burner. The carton of charcoal is set on it and, when the carton has burned completely, the briquettes are burned to required coals for cooking (¼ hour). These coals can be arranged with prongs for the best heat distribution. This is a good hibachi for shish kebabs or Dingle stick cookery. If you plan to cook a foil dinner, a cake rack placed on top of the hibachi will serve as a grid and allow good air circulation. The flower pot gets *very hot* so place it on a rock or sand to prevent scorching the grass. An aluminum foil pie tin can also serve as a charcoal burner for Brownies and hikers. Be sure it too is placed on rocks and warn the girls not to touch it. It looks harmless but it's *hot* once the coals are ignited.

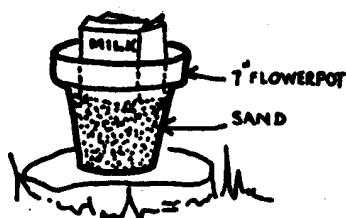
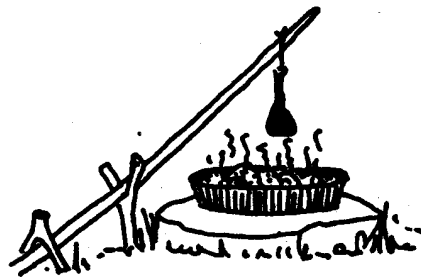

HIBACHI



If the hikers wish to cook for a patrol rather than each individual cooking on her own hibachi (but *all* need *lots* of experience with charcoal), one member of each patrol could prepare a pail for a burner and a "cake rack grid" for a grill. Charcoal fires need lots of air so the pail partly filled with sand will raise the fire for more oxygen. Be careful hikers don't put so much on top that they smother their fires. If pails are to be used for only charcoal fires, holes can be put in them at the bottom and centre to allow more draft.

Rangers and Cadets with a pair or two of tin snips, and a thrifty eye for available cans, could undertake a service project for their established camps and make a set of charcoal burners. Tin cans, lard pails, and oil cans of different shapes can be cleaned and stoves designed. Metal rods and good weight screening or fencing can be used for the grills for cooking those succulent chicken legs, pork chops, or spare ribs over direct coals.

Caution: Inexperienced charcoal users think that because they cannot see a flame it is not burning. White ash on the charcoal and warmth means it IS burning. For more heat tap this white ash from the charcoal with a stick.

Charcoal fires should be allowed to burn out, and all should be doused with water or sand. NEVER dump hot coals on the ground. They will not only burn out but ignite grass, roots, etc. and start ground fires.

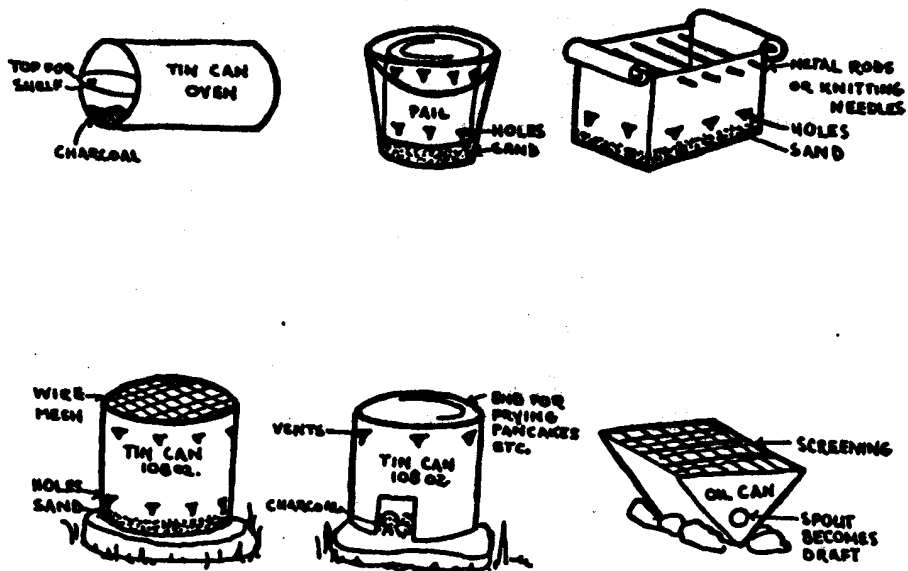

Firebugs:

Newspapers rolled tightly . . . string every 2", cut between strings . . . dip each piece (or bug) in melted paraffin wax; let cool.

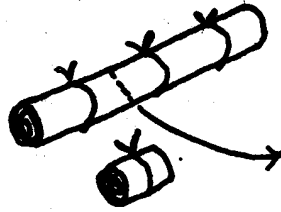

Candle stubs:



Buddy Burners:

Sardine can filled with coil of corrugated cardboard; add wick; fill with melted wax.



Tinder:

Beware of pine and elm when cooking over direct coals as their smoke will leave a taste on the food.

Fuzz Stick



LEAVE LIQUID FIRESTARTERS AT HOME - they are too volatile for children.

Include charcoal cookery in your program because charcoal is used at most National and International encampments, and of course your girls will get to one some day!

INDIVIDUAL BARBECUE

by Courtesy of "Ideas Unlimited"
The Canadian Guide, October 1964

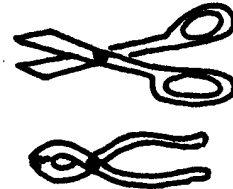
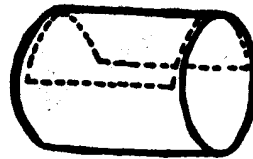
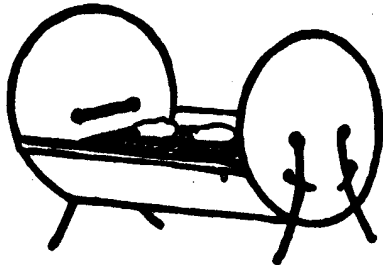

CUT OUT ON DOTTED LINE USING TIN SNIPS
HOLD WITH PLIERS

When you are going on a campout or cooking up a backyard or beach get-together, you will need one of these small grills.

MATERIALS

1-gallon heavy oil can (obtainable from most gas stations); coat hanger wire; tin snips; hardware cloth; pliers.

DIRECTIONS

Clean can thoroughly with strong detergent and soapy water. Dry. Cut side of the can with tin snips and pliers (see illustration).

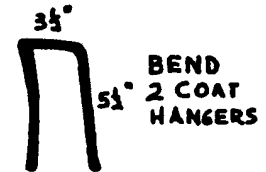
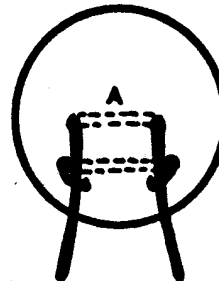
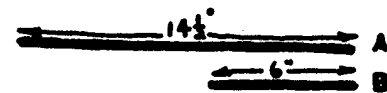
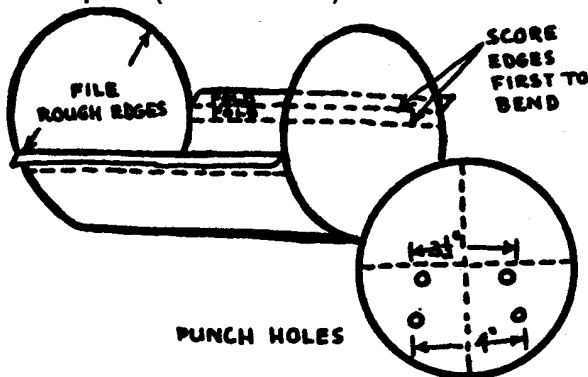

Score sides of can on dotted lines with sharp nail, then bend over twice (using pliers) so that ragged edge is turned under. File all rough edges smooth.

Punch 4 holes in both ends of can (top and bottom).

Cut 4 pieces of coat hanger wire, 2 14 1/2" and 2 6", for making legs. Push longer wires through sides as shown. Bend the shorter wires to fit through the ends of the can and across the long wires.

Bend hardware cloth on all 4 sides. Set the rack onto the grill.



BEND UNDER 1/4" ON ALL
FOUR SIDES

HOW TO MAKE A REFLECTOR OVEN The Folding Type

by Kathleen Robinson

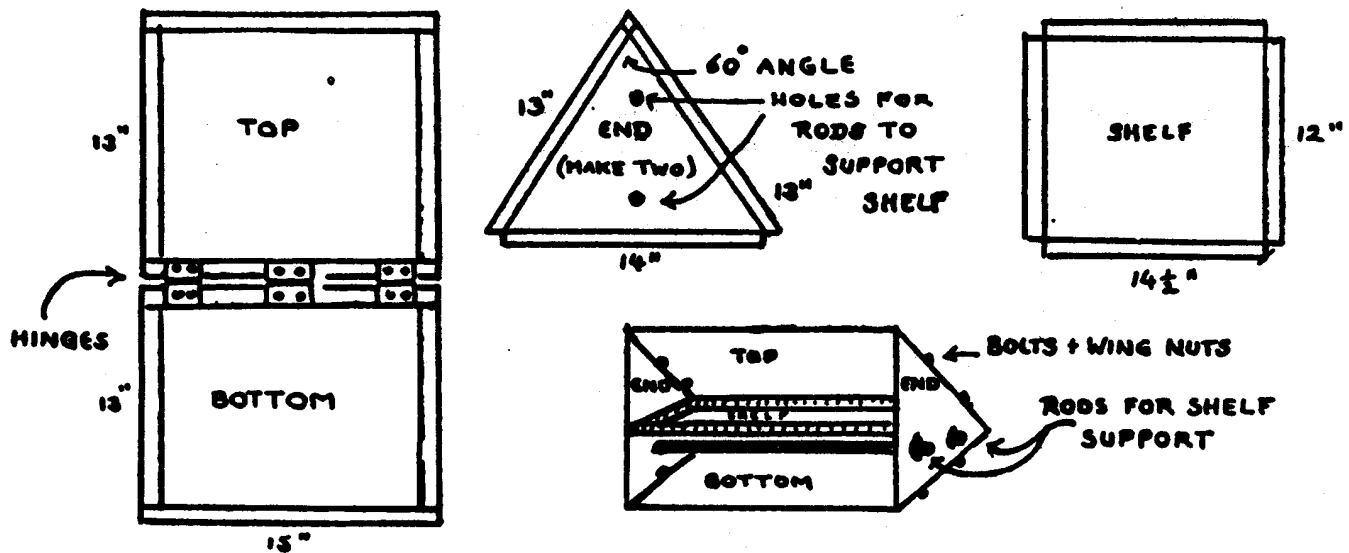

MATERIALS REQUIRED

Tin may be used, but lightweight aluminum is better and easier to work with. A $\frac{1}{2}$ " turning is allowed on all pieces. Measurements of the finished pieces are given in the diagram.

1. 2 pieces 16" x 14" for top and bottom of oven; fold $\frac{1}{2}$ " on all sides and flatten folds
2. 2 pieces (triangular) 14" x 14" x 15"; bend edges $\frac{1}{2}$ ", on short sides at right angles and, in front, fold over and flatten; make holes for rods
3. 1 piece 15 $\frac{1}{2}$ " x 13" for shelf; make $\frac{1}{2}$ turn up at right angles on all sides
4. 2 rods, 16" long and $\frac{1}{4}$ " in diameter, for shelf supports
5. 3 hinges
6. stove bolts (smallest size) and $\frac{1}{2}$ " long
7. 8 wing nuts

Use 12 of the stove bolts to fasten hinges. The hinges are evenly placed across the back of the top and bottom parts of the oven. The outside pair are not at the extreme edges. The remainder of the bolts fasten the ends of the oven to the top and bottom with wing nuts.

To fold for packing, remove shelf and rods and then the 8 wing nuts (carry a small bag for these). Lift out ends, lay shelf on bottom of oven, place rods on top of it with the 2 end pieces (together) on top of the rods, and fold down top of oven. Place in cloth bag; one with reinforced corners is best. Have flap on bag so the rods will not slide.

The movable shelf can be used as a baking sheet and saves the weight of an extra utensil.

We have cooked baking powder biscuits, cookies, cakes, pies, and bread in this oven. It is said to be equally good for roasting meat, but so far we have not used it for this.

"Pointers for Pioneers or Camp Skills for Canadian Guides"



HOT WATER AT CAMP

The Canadian Guider, March 1966

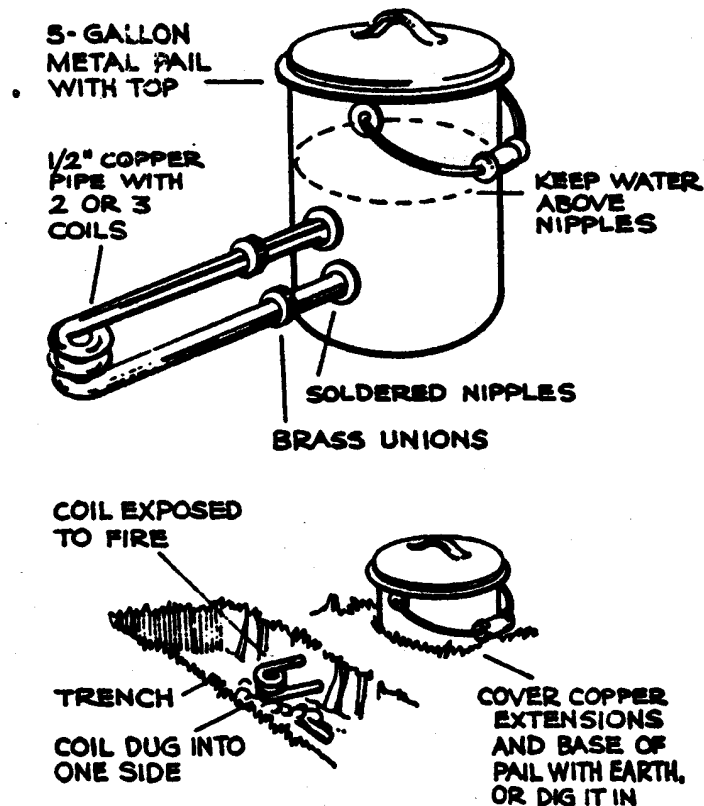

Thrill Q.M. this summer with a constant supply of hot water. Give your patrols a break and plan now to make them a GILWELL COOKER.

The plans were passed along to us by the Regina Boy Scouts, but just who thought of the original seems to be in antiquity. Its very name suggests a long time ago!

We recommend it as it is clean and thrifty. No need to build two fires; one trench fire will do for cooking and keeping the water hot. No more big boilers on the trench fire heating up and cooling off rapidly.

GILWELL COOKER

This cooker is insulated by the ground around it and there is little heat loss. If nurse is late for lunch it can serve as a double boiler too. Simply place a basin (not plastic) in the top. Put nurse's dinner on a plate in the basin and replace the lid.

You'll find it inexpensive as the cans/pails are available from restaurateurs. The copper coil and nipples are obtainable from a plumber, and no doubt your parent's committee will suggest a dad who has a soldering iron and is willing to solder a cooker for each patrol.

It is important that the coil is exposed to the fire and that the copper extensions are below the grass root line. Try it. You'll like it, and the Gilwell Cooker will serve you for years to come in trench fires of wood or charcoal.

NOTE: This water heater does not require the use of a trench fire; the copper coil can be placed in or on the coals of a wood fire or charcoal.



WATER HEATER AND INCINERATOR

The Canadian Guider, March 1965

Many camps are becoming very modern and maybe this contraption is outdated. For those of us who remain in the realm of the pioneer, this combination water heater and incinerator is a most useful friend. As the garbage is burned, the water is heated.

The garbage is placed on the top grate - fire on the second grate. Tin cans, bottles, bones, peelings, and even watermelon rinds can be burned. If one is only interested in heating water, especially in the morning, the fire is placed on the top grate.

The cost is minimal. The zinc water tank was a discard from a friend's home, the piping was donated, and the opening in the tank was made by a friendly garage person. We bought the tap, the elbow, and the stovepipe.

The diagrams are self-explanatory. The measurements for the openings, etc. do not need to be followed precisely. They are only suggested dimensions and can be adjusted to meet your specific needs.

We have used our incinerator and water heater approximately four years. The barrel will probably require replacing in a couple of years because it remains outside all winter and it is now becoming rusty. The stovepipes require replacing each spring.

We recommend it.

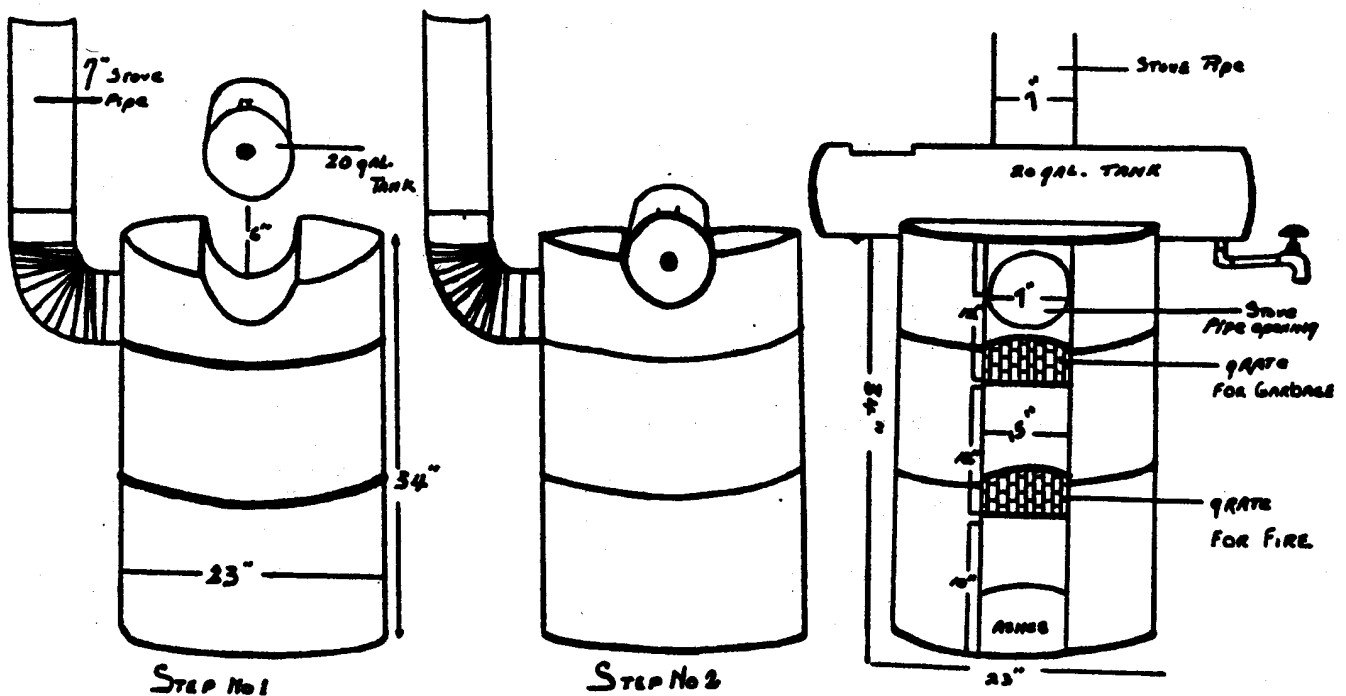

IMPROVISED COOKING METHODS

CHARCOAL B.B.Q.

Use gallon size.
Cut into 8 1/3 way down.
Fill with sand.
Line with foil and place charcoal on top. Grill can be used over this.

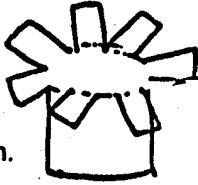

CAN OVER CAN OVEN

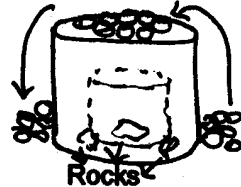

Put food in small can on coals, cover.

Unless cooking in fire pit - coals must be off the ground



Cans and barrel lid

REFLECTOR OVEN

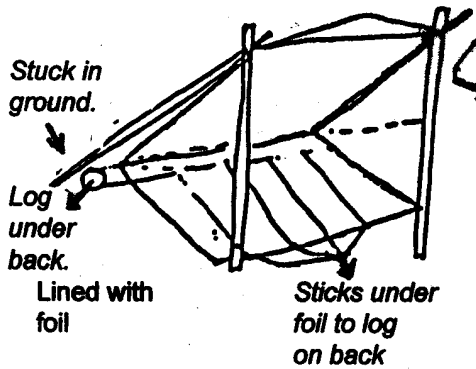

Rack placed inside on top of log at back - rocks under front to keep level

CAN IN CAN OVEN

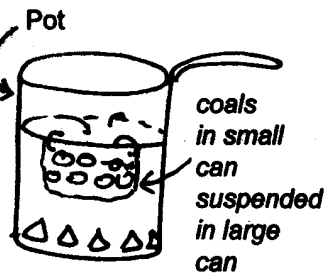

CAN IN CAN OVEN

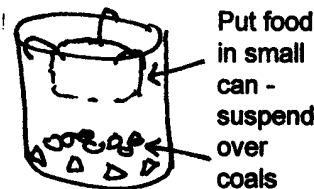

Put food in small can - suspend over coals

COAT HANGER ROASTING STICK

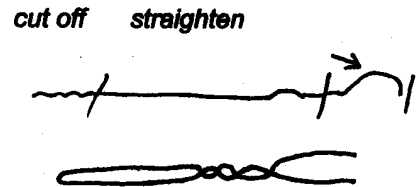

PAIL COOKING

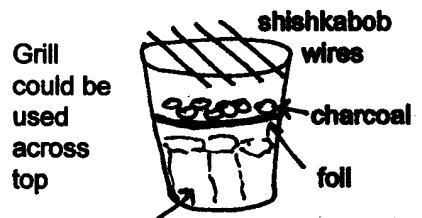

Empty cans or dirt.

DINGLE FAN

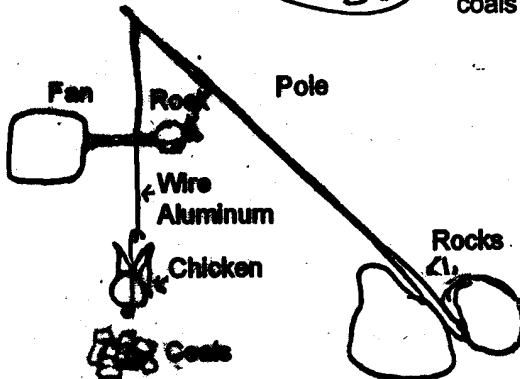

Tie wire through and around side of chicken

EGG ON A PIN

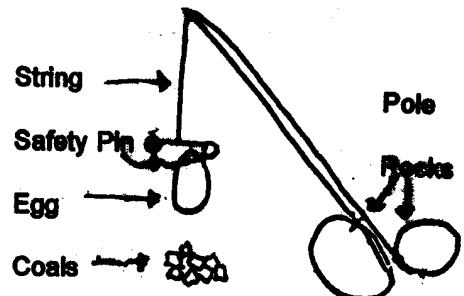

BREAKFAST

	Page
Laura White's Easter Breakfast	21
Breakfast Souffle	21
Egg McMuffin	22
Eggs in Foil	22
Eggs in a Basket	22
Edna's Porridge	23
Edna's Porridge in a Hay Box	23
Fruit Porridge	24
Granola	24
Pancakes with a Flair	25
"Maple" Syrup for Pancakes	25
Toppings for Pancakes	25
Oven Pancakes for 30	26
Breakfast in a Bag	26

LAURA WHITE'S EASTER BREAKFAST

Cooking method: Oven 350°F

Cooking time: 45 minutes

Servings: 8

Ingredients: 2-lb bag hash browns, thawed
1 pint sour cream
1 can cream of chicken soup
1/2 cup chopped onion
1/2 cup melted butter
2 cups grated cheddar cheese
salt and pepper to taste
cubed meat, ham, bacon, etc. (optional)
2 cups crushed cornflakes
1/4 cup melted butter

Combine first 8 ingredients. Place in an 8" x 10" baking dish. Mix the cornflakes with second amount of butter and spread on top. Bake at 350° for 45 minutes.

Linda Rothenburg
Edmonton

BREAKFAST SOUFFLE

Cooking method: Box oven, Oven 350°F

Preparation time: Overnight

Cooking time: 45 minutes

Servings: 6 - 8

Ingredients: 5 slices of bread, cubed
8 oz. cheddar or mozzarella cheese or both, cubed
1lb bacon, cooked and crumbled
2 cups milk
3 eggs

Combine eggs and milk and beat.
Combine bread, cheese and bacon in 9" x 12" baking dish.
Pour egg, milk mixture over this.
Cover and store in fridge overnight.
Bake uncovered for 45 minutes.
Tastes good hot or cold.



Alice Filipchuk
Edmonton

EGG McMUFFIN

Cooking method: Stove top or open fire
Cooking time: 30 - 45 minutes
Servings: 1
Ingredients: 1 crumpet (cut in half)
1 slice cheese
1 slice ham
1 egg

Toast the crumpet over open fire and fry the egg and ham in a frypan (cook the egg hard). When done, put into crumpet. Wrap the whole thing in foil and set on grate over hot coals until cheese melts.

Takes about 1/2 hour, turning occasionally.

Bev Jaeger
Parkland

EGGS IN FOIL

Cooking method: Foil cooking
Cooking time: 7 - 10 minutes
Servings: 1
Equipment: 1 - 7" piece of foil
1 - 1lb can
Ingredients: Egg, 1 or 2 per person



Make a foil cup by moulding the foil around the bottom of the can. Crack an egg into the foil cup and cook directly on the coals 7-10 minutes or until desired consistency.

Arlene Salyzyn
Edmonton

EGG IN A BASKET

Cooking time: Stove top, buddy burner
Servings: 1
Ingredients: 1 slice bread
1 egg
oil

Remove 2" circle from the middle of the bread. Put small amount of oil in skillet and fry bread with the centre removed. When slightly brown, turn and slightly brown the other side. Drop uncooked egg in centre of bread. When underside is done, turn and cook other side to taste.

Julie Nielsen
Tamarac

EDNA'S PORRIDGE

Cooking method: Stove top

Preparation time: 15 - 20 minutes overnight

Cooking time: 15 - 20 minutes

Servings: 36

Ingredients:

- 1 lb raisins
- 2 lbs dried apples, cut into small pieces
- 12 cups oats
- 3 tsp salt
- 3 - 5 tbsp brown sugar
- 1 tbsp margarine
- cinnamon to taste
- 26 cups water
- 2 litres apple juice

Soak raisins and apples in water-juice mixture overnight. In the morning, bring water to a boil. Add brown sugar to water and stir to dissolve. Add oats **gradually**. To prevent lumpy porridge the secret is to add some and stir until you have added the entire quantity needed. Keep stirring as the porridge is thickening. Make sure you reach the bottom so it won't stick. Add margarine and cinnamon for flavour. If porridge appears too thick, while stirring, gradually add some more water. Soak pot immediately after use for easy cleaning.

Edna Dach
Edmonton

EDNA'S PORRIDGE IN A HAYBOX

Cooking time: Overnight

Bring water and apple juice to a boil. Add the other ingredients as directed above, bring to a boil and remove from heat. Put in haybox overnight (see Haybox instructions, page 5).

Carol Buss
Edmonton

FRUIT PORRIDGE

Cooking method: Stove top or open fire
Cooking time: 3 - 5 minutes

Servings: 4 - 6

Ingredients: 3 cups water
1 apple, chopped
1/4 cup dates, chopped
• 4 tbsp brown sugar
1½ cups oats

Boil water and stir in dates, brown sugar and apples.

When fruit is cooked, gradually stir in rolled oats. Cook and stir for 3 - 5 minutes or until mixture thickens.

Julie Nielsen
Tamarac

GRANOLA

Ingredients: Bowl #1:
2 lbs rolled oats
2 cups wheat germ
1 cup wheat bran
1lb each: sliced cashews, almonds, and hulled sunflower seeds
1 tbsp salt

Bowl #2:
1½ cups safflower oil
2/3 cups water
3 tbsp vanilla extract
2 cups honey

Combine mixture of second bowl with first. Mix well. Spread about half-inch thick on oiled cookie sheets. Place in slow oven (250°F) for 1 - 1½ hours. Turn mixture thoroughly after first half hour and then again every 15 minutes until oats are golden brown. Let cool. Add raisins or other dried fruit.

Kay Quon
Edmonton

PANCAKES WITH A FLAIR

Cooking method: Buddy burner or stove top

Cooking time: About 2 minutes per pancake

Ingredients: Pancake mix, for amount needed
Canned fruit, or fresh fruit, chopped
Butter or margarine
Toppings (whipped cream, maple syrup, etc.)

Place butter in pan or on buddy burner to melt; add fruit pieces for one pancake and cook for 10 seconds. Cover with pancake mix and cook on both sides. Serve with topping of your choice. Fruit can be shaped into faces or designs for that extra touch.

Susan Ruzek
Calgary

'MAPLE' SYRUP FOR PANCAKES

Combine: 1 cup boiling water
2 cups brown sugar
1/2 tsp mapleleene

Marlace Susut
Parkland

TOPPING FOR PANCAKES

For a change from b-o-r-i-n-g butter and syrup on your pancakes, why not try thawed frozen fruit? The containers of frozen strawberries or raspberries, complete with juice, have been most popular.

Top pancakes with fruit and add a spoonful of thawed frozen whipped topping (Cool Whip, etc.) on top of the fruit and the girls will be delighted with the change of fare.

For 8 - 10 servings: 1 container frozen fruit
1 500ml container Cool Whip

Irene Pettapiece
Edmonton

OVEN PANCAKES FOR 30

Cooking method: Oven 450°F

Cooking time: 15 minutes

Servings: 30

Ingredients:

- 6 eggs
- 3 cups milk
- 3¾ cups flour
- 9 tsp baking powder
- 3 tsp white sugar
- 1½ tsp salt
- 6 tbsp melted shortening

Beat eggs and milk together until fluffy. Sift dry ingredients together. Add dry ingredients and shortening to milk mixture. Beat until smooth; pour into greased cookie sheets and bake for 15 minutes at 450°.



**GOOD
MORNING!**

Glen Allen District
Edmonton

BREAKFAST IN A BAG

Cooking method: No utensil, open fire

Cooking time: 20 minutes

Servings: 1

Ingredients:

- 1 brown paper bag, lunch size
- 1 egg
- 2 strips bacon
- salt and pepper
- 1 stick

Lay strips of bacon in the bottom of the bag. Break egg on top of bacon. Salt and pepper to taste. Fold top of bag down and poke stick through top of bag. Cook over hot coals for 20 minutes, making sure the bag does not touch flame or coals.

Marni Staszko
Edmonton

SOUP, SALAD, SANDWICHES

	Page
Soups	
Stone Soup	27
Cloud Swallow (Wonton) Soup	28
Friendship Soup	29
Turkey Soup	29
Hearty Hamburger Soup	30
Hamburger Soup	30
Salads	
Tuna Macaroni Salad	31
Onion Salad	31
Sweet and Tart Salad	31
South of the Border Salad	32
Veggie Dip	32
Hiker's Salad	32
Sandwiches	
Reuben Burgers	33
Hot Tuna Sandwiches	33
French Cheese Sandwiches	33
Cheese Tuna Sandwiches	34
Italian Buns	34
Wiener Roll-ups	34
Snowy Wieners (an honorary sandwich)	35

STONE SOUP

Cooking method: Stove top or fire

Cooking time: 2 hours

Servings: 24

Most Brownies are familiar with the story "*Stone Soup*", which tells how two travelling soldiers trick a village into sharing their hidden bounty and make a pot of soup for all to share.

Read the story to the girls, substituting the ingredients which you want included. Then send the girls off to scrounge the ingredients from the camp cooks (warn them well ahead of time!)

When all have gathered together again, read over the part of the story which concerns the ingredients and have the girls add theirs at the same time.

For 24 you will want:

1 VERY large pot with lid
2 big spoons
1 sharp knife
1 cutting board
1 stone, SCRUBBED CLEAN
18 cups of water
salt
pepper
lemon juice
2 cups of noodles OR
1 cup rice
butter
parsley
bay leaf

12 cups of mixed vegetables, including:

onions
celery
cabbage
carrots
corn
peas
potatoes (raw or hash browns)
tomatoes
beets

2 lbs meat, chopped: chicken
beef
bacon, cooked and crumbled
hamburger, browned and drained

Bring water to a boil. Brown meat, onions, celery in butter. Put stone in pot; add all other ingredients. Cover and cook, stirring occasionally, for 2 hours.

Save the stone for next time!

Glen Allan District
Edmonton

CLOUD SWALLOW (WONTON) SOUP

Cooking method: Patrol cooking, stove top, or open

Cooking time: 10 minutes

Preparation time: 1 hour

Servings: Patrol of 4

Ingredients:

- Chicken broth (6 - 8 fl oz per girl)
- Soup noodles (optional)
- 2 cups or less of minced meat*
- ½ tsp salt
- 1 tbsp soya sauce
- ½ lb (usually 36 - 40) wonton skins
- 1 stalk scallion (or sprig of parsley)

Equipment:

- 3 qt pot for broth
- 3 qt pot for boiling water
- 1½ pt bowl for the meat mixture
- small bowl of water
- knife
- chopping board
- mixing fork or spoon
- teaspoon

Mince meat. Combine well with salt and soya sauce. Wrap mixture - up to a rounded tsp in amount - as illustrated below. Drop wontons into *boiling* water. Cook until they float (about 10 minutes). Drain. Add cooked wontons and chopped scallion or parsley to hot broth. Serve in bowls.

Notes: * The meat may be leftovers - single or in combination - cooked or raw. Beef or chicken would be best. If on hand, add in a beaten egg as a binder.

Besides using up leftovers, wonton wrapping is a novel way for Guides to participate in food preparation. Allow an hour from start to clean-up.

As a food item, wontons with or without the broth would be suitable for noon lunch, part of a meal, daytime or evening snack after campfire - almost anytime. For cooking method and food appeal, this recipe would be suitable for Guides to Guiders!

Source: the basic recipe is standard to most Chinese cookbooks. I have adapted and tested it at Guide camp.

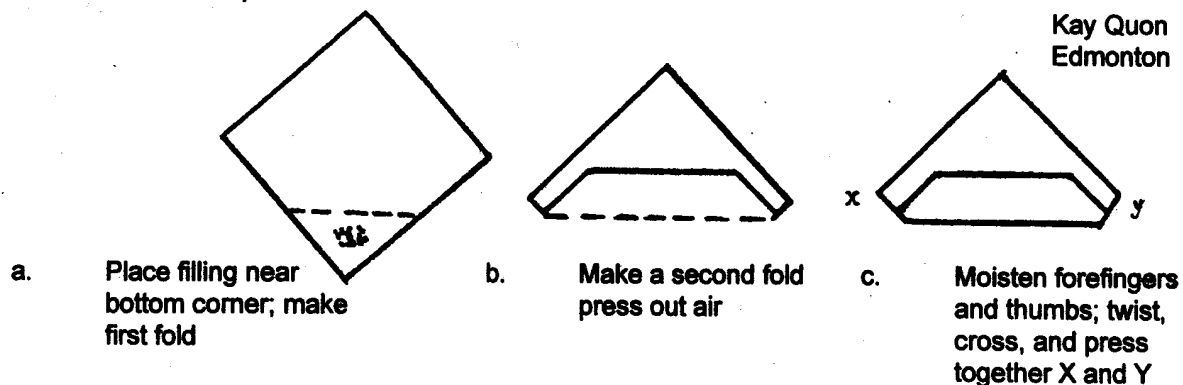

FRIENDSHIP SOUP

Cooking method: Stove top or open fire

Have each girl bring a can of soup. It is best if cream soups are excluded. Open cans and mix in a large pot with appropriate amount of water. Delicious.

Janet Stafrace
Edmonton

TURKEY SOUP

Cooking method: Stove top

Cooking time: For stock: 2 hours or 30 minutes in pressure cooker
For soup: 45 minutes or 5 minutes in pressure cooker

Servings: Large group

Ingredients: Turkey bones and leftovers from turkey supper served earlier in camp

For soup, add to stock:

1 large onion, chopped
6 large carrots, sliced
6 stalks of celery, sliced
Any leftover vegetables such as peas, corn, or mixed vegetables
Leftover gravy
2 pkgs chicken noodle soup mix

To prepare stock cover turkey bones, neck, and leftovers with water, and cook for 2 hours or 30 minutes in a pressure cooker at 15 lbs. Cool and remove all bones.

Add vegetables and other ingredients to stock. Cover and cook for 45 minutes or 5 minutes in a pressure cooker at 15 lbs.

Ideal for winter residential camp (and economical too !!!)

Mary McKenzie
Parkland



HEARTY HAMBURGER SOUP

Cooking method: Stove top

Cooking time: 45 minutes

Servings: 12 - 16

Ingredients:

- 2 lbs ground beef
- 2 cups carrots, sliced
- 2 cups celery, sliced
- 2 cups onions, chopped
- 6 cups water
- 1 14oz can tomatoes
- 2 beef bouillon cubes dissolved in 2 cups of water
- 2 tbsp Worcestershire sauce
- Salt and pepper to taste



Brown hamburger and drain off fat. In a large kettle cook vegetables in water for 5 minutes. Add meat and remaining ingredients to kettle. Cover and simmer for 30 minutes.

Vary recipe as desired. Frozen mixed vegetables can be added. Soup may be thickened with $\frac{1}{2}$ cup flour mixed with cold water. Especially good served with Italian bread or crusty buns.

Eleanor Grundberg
Edmonton

HAMBURGER SOUP

Cooking method: Stove top

Cooking time: 1 - 2 hours

Servings: 4 - 6

Ingredients:

- $\frac{3}{4}$ lb ground beef
- 1 medium onion, chopped fine
- 1 19 oz can tomatoes
- $3\frac{1}{2}$ cups water
- 3 beef bouillon cubes
- $\frac{1}{2}$ can tomato soup
- 2 carrots, chopped fine
- 2 stalks celery, chopped fine
- parsley (optional)
- 4 tbsp barley, rice, or macaroni

Brown hamburger with onions. Drain well. Combine all ingredients in a large pot. Simmer until vegetables are tender.

Variation: Dumplings may be made and spooned into soup mixture. Cook approximately 15 minutes longer with lid on.

Julie Nielsen
Tamarac

TUNA MACARONI SALAD

Servings: 6

Ingredients: 4 cups cooked macaroni
1 small onion, chopped fine
¼ cup chopped celery
3 hard boiled eggs
1 7oz can tuna
½ green pepper
¾ cup medium cheddar, diced
salt and pepper
1 cup mayonnaise

Combine ingredients. Chill and serve

Marni Staszko
Edmonton

ONION SALAD

Slice 6 Spanish onions thinly.

Soak in: ½ cup water
½ cup vinegar
¾ cup sugar
2 tsp salt

Soak for three hours. Drain well and add 1½ cups Miracle Whip Salad Dressing and 3 tsp celery salt.

Marni Staszko
Edmonton

SWEET AND TART SALAD

Ingredients: Oranges, peeled and sliced
Tomatoes, sliced
Red and white onion, peeled and thinly sliced

Quantities: *Per person -* ½ orange
1/3 tomato
1/6 onion
Per 24 - 12 oranges
8 tomatoes
4 onions

Arrange slices in rows on a platter and drizzle with bottled creamy Italian or Golden Caesar dressing.

Glen Allan District
Edmonton

SOUTH OF THE BORDER SALAD

Servings: 24

Ingredients: 12 tomatoes, coarsely chopped
2 or 3 avocados, peeled and coarsely chopped
1 14oz can pitted black olives, drained, halved
2 12 oz cans kernel corn, drained
2 19oz cans chick peas (garbanzos), drained
2 red and 2 green peppers, seeded, chopped
• 1 lb Monteray Jack cheese, cubed
2 or 3 heads lettuce, bite size chunks
Mild taco sauce or Mexican-style salad dressing
3 bags taco chips

Toss the first 8 ingredients together . Each girl adds her own taco sauce and chips.

This salad is a hearty meal, and needs only a drink and dessert to follow.

Glen Allan District
Edmonton

VEGGIE DIP

Ingredients: 1 pkg Knorr Vegetable Soup mix
(make sure the powder is firmly crumbled into fine pieces)
1 large container of sour cream

Mix well and serve with all sorts of vegetables.

Phyllis Clow
Edmonton

HIKER'S SALAD

Ingredients: 1 apple
½ tsp salad dressing
1 tbsp cottage cheese
About 10 raisins
1 tsp walnuts

Cut top off apple and core it, leaving bottom skin to form a cup. Scoop out inside of apple, being careful not to break skin. Chop apple and mix with rest of ingredients. Stuff into apple skin. Put lid back on and wrap in plastic or foil. Can be eaten while hiking.

Julie Nielsen
Edmonton

REUBEN BURGERS

- Cooking method: Fire, stove top or foil
- Cooking time: Approximately 5 minutes
- Servings: Individual
- Ingredients: 1 freshly cooked hamburger patty
1 slice mozzarella cheese, or cheese of your choice
1 - 2 tbsp sauerkraut, well drained
2 slices rye bread (heavy rye is best)

Butter the *outside* of both pieces of bread. Place beef patty on bottom piece (on unbuttered side), then sauerkraut on top, and then cheese on top of that. Place other piece of bread, unbuttered side down on sandwich. Cook sandwiches in a fry pan over medium heat until browned on both sides. Alternatively, wrap in foil and heat over coals.

Variations: Add mustard and other condiments of choice. A mixture of equal portions of prepared mustard and green pickle relish with a bit of chopped onion is good.

Betty Quinn
Edmonton

HOT TUNA SANDWICH

- Cooking method: Stove top or fire
- Servings: 5
- Ingredients: Tuna sandwiches to taste
2 eggs (for 5 sandwiches)

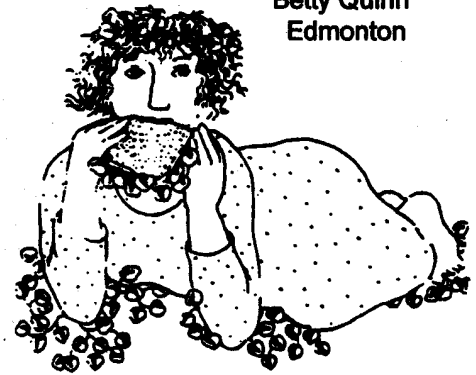

In separate bowl beat 2 eggs. Dip prepared sandwiches in egg, covering both sides. Grill on both sides until golden brown.

Ann Fulton
Edmonton

FRENCH CHEESE SANDWICHES

- Cooking method: Stove top or fire
- Ingredients: eggs
milk
bread slices
cheese slices

Mix eggs and milk as for French toast. Put cheese slices between two slices of bread. Dip sandwich in egg mixture and cook as you would French toast. Serve with syrup.

Variation: Add ham slices

Carol Buss
Edmonton

CHEESE TUNA MUFFINS

Cooking method: Oven (broil)
Cooking time: 3 minutes
Servings: 6
Ingredients: 1 can tuna, drained and flaked
1 cup grated Swiss cheese
• ½ cup mayonnaise
1 tsp Worcestershire sauce
6 English muffins, split and lightly toasted

Mix ingredients and spread on 12 muffin halves. Broil 3 inches from heat for 3 minutes.

Betty Evans
Edmonton

ITALIAN BUNS

Cooking method: Oven (broil)
Cooking time: 5 minutes
Servings: 2 cups per patrol of 4
Ingredients: 1 can Prem or any prepared meat - grind
4 oz cheddar cheese - grated
1 small onion - chopped
1 tbsp catsup
½ tsp dry mustard
1 tsp Italian seasoning
½ cup Miracle Whip

Mix ingredients together and spread on buns. Broil for approximately 5 minutes.

Betty Evans
Edmonton

WIENER ROLL-UPS

Cooking method: Box oven
Ingredients: wieners
cheddar cheese
Pillsbury dough

Slice wieners lengthwise and fill with cheese. Wrap in Pillsbury dough square. Secure with toothpicks. Bake in box oven until dough is cooked (browned).

Variations: Bannock may be used but should be kept fairly thin. Cheese slices may be wrapped around wiener instead of stuffing with cheddar.

Marlace Susut
Parkland

SNOWY WIENERS

Cooking method: Oven, reflector oven, box oven, foil cooking

Cooking time: 15 minutes

Servings: Any number: 1 wiener per Brownie
2 - 3 wieners per older girl

Ingredients: Per serving:
1 wiener
½ cup hot mashed potatoes (real or instant)
2 - 3 tbsp grated cheddar cheese
mustard (optional)
onion, finely chopped (optional)

Split wiener lengthwise, almost all the way through. Press open. If wieners are heated first in hot water, they are easier to cut. This also saves time in cooking. Spread wiener with a thin layer of mustard, if desired. Combine hot mashed potatoes with cheese and mix well; add onion if desired. Pile onto wiener. Place in shallow pan under broiler or in hot (425° F) oven until cheese is melted; about 10 minutes. When using foil, wrap loosely and do not turn over while heating.

Alice Filipchuk
Edmonton

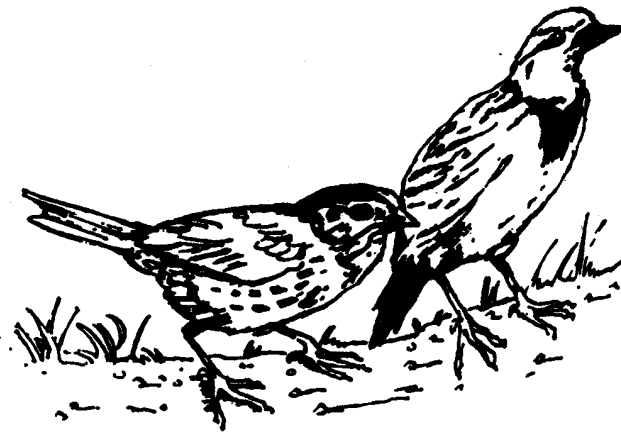

BREADS AND BISCUITS

	Page
Welsh Cakes	37
Edna's Welsh Cakes	37
Bannock I	38
Bannock II	38
Doughboys I	39
Doughboys II	39
Skillet Biscuits	40
Baking Powder Biscuits	40
Drop Biscuits	41
Quick Bread	41
Two Hour Buns	41
Hobo Bread	42
Flutterby Buns	42
Okeekun Camp Baking Mix	43
Tin Can Bread	44

WELSH CAKES

Cooking method: Stove top, buddy burner, open fire

Cooking time: 20 minutes

Servings: 4 - 8

Ingredients;	1½ cups flour	Stir together in bowl or large ziplock bag.
	pinch of salt	
	pinch of nutmeg	
	¼ tsp cinnamon	
	1 tsp baking powder	
	1 cup margarine	cut into flour mixture to resemble bread crumbs
	½ cup white sugar	stir into main mix
	½ cup raisins	
	1 egg, slightly beaten	stir this into main mix
	2 tbsp milk	

Roll out dough on floured surface to ¼" thick, or flatten large spoonfuls of dough between hands. Cut out biscuits with glass or open end of can. Melt margarine in pan over medium heat. Fry biscuits, a few at a time in pan, on each side until brown. Serve warm and sprinkle with sugar or spread with butter.

Recipe source: Girls from Wales visiting Our Chalet, August 1984.

Nancy Hathaway
Tamarac

EDNA'S WELSHCAKES

Cooking method: Stove top

Ingredients: 3 cups flour
4 tsp baking powder
½ tsp salt
¾ cup currants or raisins
½ cup sugar
2 eggs
½ cup margarine
¾ cup milk

Mix flour, baking powder, and salt. Rub in margarine as for pastry. Stir in fruit and sugar. Beat eggs slightly, add along with some milk to make a doughy pastry consistency. Roll ¼" thick. Cut in circles 2 - 2½" in diameter. Bake in an electric frypan or on stove till light brown. Turn once.

Edna Dach
Edmonton

BANNOCK I

Cooking method: Stove top or fire

Cooking time: 15 minutes

Ingredients: 1½ cups flour
½ tsp salt
½ cup oatmeal
1 tsp soda
3 - 4 tbsp bacon dripping (or margarine)
1 cup buttermilk

Stir together flour, salt, oatmeal, and soda. Rub in bacon dripping or margarine. Stir in buttermilk quickly. Knead slightly on floured board. Pat out to ½" thickness. Heat cast iron frying pan to 375°. Sprinkle a small amount of flour into pan. Cut dough into 10-12 squares. Place dough into pan ½" apart. Cook until nut brown, approximately 7 minutes per side.

Eleanor Grundberg
Edmonton

BANNOCK II

Cooking method: Stove top, open fire, box oven, oven

Ingredients: 2 cups flour
½ tsp salt
2 tsp baking powder
1 tsp sugar
3 - 4 tbsp oil
¾ cup water
raisins (optional)

Mix dry ingredients. Add oil and mix well. Add water and knead. Press dough into pan and cook over fire, in an oven, etc.

Variations: Cook on a stick (see next recipe).
Cook in small patties in frying pan.
Good with grated ch ese.

For backpacking: Place ingredients in a ziplock bag. Add water when ready to use.

Marlace Susut
Parkland

DOUGHBOYS I

Make up a bannock recipe from scratch or use a biscuit mix. Each girl covers the end of a rounded broom-stick with tin foil and presses her bannock over this. Roast over an open fire until baked through. Carefully pull the bannock off the stick and remove foil if stuck to the inside. Fill with jam, butter, etc.

Glen Allan District
Edmonton

DOUGHBOYS II

Cooking method: On a stick, over hot coals

Servings: 1

Ingredients ½ cup flour
 1 tsp baking powder
 1 tsp shortening
 Pinch of salt
 ¼ cup water
 a little extra flour

Mix dry ingredients. Add shortening and mix in with fingers (clean preferably). Add cold water *slowly* making dough stiff enough to hold together. Heat stick and flour it. Wrap dough on stick, winding it on like a ribbon. Squeeze gently. Cook 5 inches away from coals, turning continually till golden brown. Slip off stick. Stuff hole with jam, bacon, chopped meat, etc.

Variations: Biscuit mix can be used for short cut.

Tips: When wrapping dough on the stick, make sure it is not too thick.
 For easy mixing of dough, use ziplock bag as bowl.
 Hands remain clean and mess is contained.

Lorna Smith
Parkland

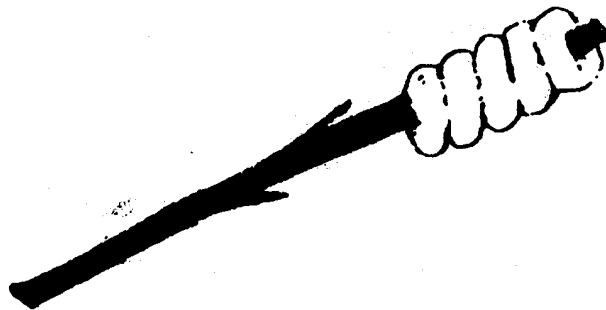

SKILLET BISCUITS

Cooking method: Fire, one burner stove, stove top

Servings: 4

Ingredients: ¼ cup butter or margarine
2 cups biscuit mix
½ cup water

Mix the biscuit mix and water with a fork. Make sure all the dry mix has been moistened. Melt butter in a heavy cast iron skillet.

Variation 1: Cheesy biscuits

Remove the skillet from the heat. Sprinkle the melted butter with a dash of onion powder, garlic salt, and paprika. Divide the dough into 8 portions and drop into skillet. Push a half-inch cube of cheddar cheese into each biscuit. Check halfway through to make sure the biscuits are not burning.

Variation 2: Orangey biscuits

Remove the skillet from the heat. Divide the dough into 8 portions and drop into skillet. Push a sugar cube into each biscuit. Drizzle each sugar cube with 1 teaspoon orange juice. Return to heat, cover and cook as above.

Glen Allan District
Edmonton

BAKING POWDER BISCUITS

Cooking method: Fire, stove top

Ingredients: 2 cups flour
3 tsp baking powder
½ tsp salt
1/3 cup cooking oil
2/3 cup milk

Mix ingredients together, roll into balls and flatten a little. Put in frying pan and cook.

- Variations:**
1. Roll around boiled sausages and roast in hot coals.
 2. Use as bannock, cooking as one large biscuit (20 minutes).
 3. Add raisins, fry the biscuits and roll in white sugar.

Julie Nielsen
Tamarac

DROP BISCUITS

Cooking method: Reflector oven
Cooking time: 15 minutes
Servings: 16 small or 8 large

Prepare biscuit dough as directed on package of buttermilk baking mix. Drop by spoonfuls onto greased, shiny side of heavy duty foil. Bake in reflector oven about 15 minutes or until brown.

Arlene Salzyn
Edmonton

QUICK BREAD

Cooking method: Stove top or open fire
Servings: 2 - 3
Ingredients: 1½ cups flour
1 tsp baking powder
1 egg
1 175ml container fruit yogurt, Swiss style

Mix dry ingredients in a ziplock bag. Beat the egg and add the egg and yogurt to dry ingredients. Knead the ingredients in the bag. Dough should be stiff and slightly sticky. Form dough into 2 or 3 balls. Flatten each ball and place in a greased pan on high heat. When that side is cooked, flip and cook the other side. Great served hot with butter!

Susan Ruzek
Calgary

TWO HOUR BUNS

Cooking method: Oven, 350°
Preparation time: 1½ - 2 hours
Cooking time: 15 - 20 minutes
Servings: 4 - 5 dozen buns
Ingredients: 3 cups water
3 tbsp sugar
6 tbsp oil
2 tbsp Fermipan yeast
2 eggs
7 - 8 cups flour
2 tsp salt

Mix yeast plus 4 cups flour. In a separate large bowl whip eggs, sugar, oil and water. Add flour-yeast mixture to this. Blend well. Add salt plus remaining flour. Let rise for 15 minutes, punch down (do not knead) and let rise for another 15 minutes. Shape into buns. Let rise for 1 hour in a greased pan. Bake at 350° for 15 - 20 minutes.

Julie Nielsen
Tamarac

HOBO BREAD

Cooking method: Oven, Dutch Oven

Preparation time: Overnight

Cooking time: 1 hour

Servings: 6

Ingredients:

- 2 cups raisins
- 2 cups hot water
- 2 tsp soda
- 1½ cups sugar
- 1 cup flour
- 2 tsp oil
- 2 tsp vanilla
- 1 cup chopped nuts (optional)

Combine raisins, water and soda and let stand overnight. Add the rest of the ingredients. Put into 3 No. 2½ size cans that have been well-greased and floured. Bake in Dutch Oven over medium coals for 45 minutes or until knife comes clean. May also be baked in 350° oven for 1 hour or until knife comes out clean.

M. J. Chambres
Montana

FLUTTERBY BUNS

Cooking method: Oven, 400°

Cooking time: 13 - 17 minutes

Servings: 6 - 8 flutterbys

Ingredients:

- 1 9.5 oz refrigerated cinnamon rolls or buttermilk biscuits
- 1 can Betty Crocker icing
- 1 small bottle maraschino cherries
(9 - 10 cherries/package of rolls)
- Whole cloves to make antenna

Heat oven to 400°. Separate rolls and cut in half. Place halves together (curved edges) on a greased cookie sheet. Stick cloves on top to make antennas. Bake for 13-17 minutes until golden brown. Remove from pan and decorate rolls with icing to make them look like butterflies. Place cherries on icing.

Tips: Icing can be spooned into small sandwich bag; secure opening and cut off 1/8 inch from one bottom corner. Squeeze icing through opening to decorate.

Phyllis Allan
Edmonton

OKEEKUN CAMP BAKING MIX

Cooking method: Wood fire or stove top

Ingredients: 1½ cups unbleached flour
½ cup commeal
½ cup soya flour
½ cup wheat germ
6 tbsp baking powder
1 tbsp salt
1 cup instant milk powder
1/3 cup sugar (optional)

Thoroughly blend together all ingredients and package in airtight plastic containers. Makes 5 cups. In camp you just add water and oil, then bake over camp fire.

Biscuits 2 small cups baking mix
½ cup (approximately) water
3 tbsp oil

Makes 8 biscuits

Stir with a fork until just blended. Dust your hands with mix, shape dough into a ball and divide into 8 portions. Pat into a flattened round about 2½ inches in diameter and ½ inch thick. Put 2 tablespoons oil in frying pan over medium heat. Add as many biscuits as can fit without crowding and cook slowly. Watch them carefully. When one side is golden brown, turn and cook the other side.

This may also be used for muffins in orange peel cups.

Pancakes 1 cup baking mix
1 egg
2 tbsp salad oil
½ cup milk or water

Mix ingredients and beat well. Fry in oiled frying pan until bubbly. Turn.

Dorothy-Ann Burgess
Chinook

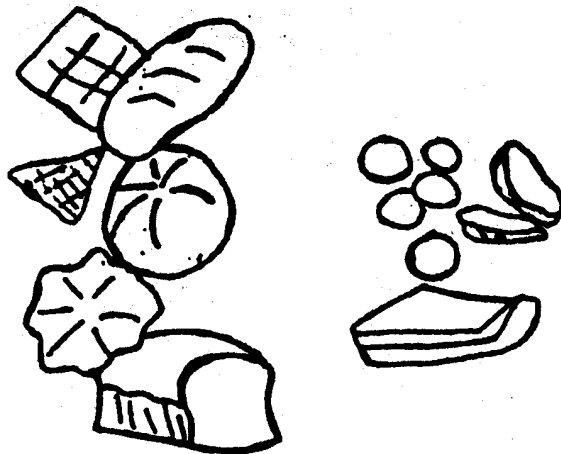

TIN CAN BREAD

- Cooking method:** Stove top, fire
- Cooking time:** 30 - 40 minutes
- Servings:** 4
- Equipment:** 10 oz. can (fruit, soup, etc), 1 per person
Can use large tuna can but more care is needed
• Aluminum foil
Large pot with lid
- Ingredients:** 1½ cups biscuit mix (Bisquick, Tea Bisk, etc.)
½ cup cornmeal
¼ tsp salt
2 tbsp sugar
½ cup raisins
¾ cup milk
2 tbsp oil

Combine dry ingredients in bowl or ziplock bag. Add ¾ cup milk and 2 tbsp oil. For 2 servings, spoon approximately ½ cup of batter into each of 4 greased cans. Cover cans with foil. Place cans in a pot of boiling water. The water level should be halfway up the cans. Cover the pot and steam 30 - 40 minutes. Cool slightly and shake bread out. Good with stews, beans and chili.

Variation: Use granola instead of cornmeal and serve with honey or jelly.

Note: Care must be taken when cans are placed in pot and when removed. This step should be well supervised.

Recipe source: Based on recipe from Girl Guides of Canada, Ontario Council, "Bits and Pieces".

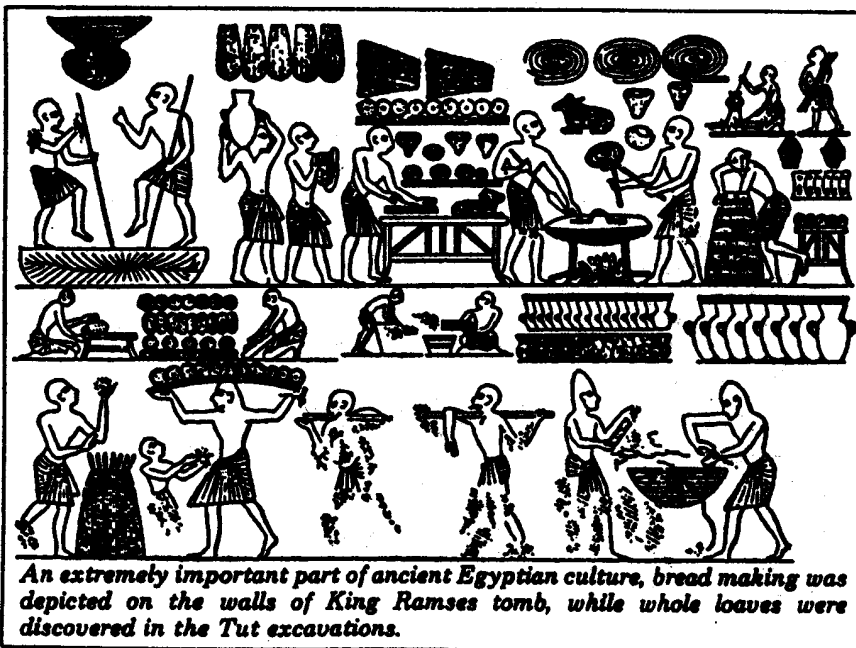

Margaret Campbell
Edmonton

DINNERS, MAIN DISHES, VEGETABLES

The recipes in this section have been arranged according to cooking method, however most recipes can be adapted to the cooking method of your choice.

	Page
Hay Box	
Hay Box Stew	45
Sweet and Sour Pork and Veggies	46
Reflector Oven, Box Oven, Oven	
Sata Ajam	47
Cabbage Bread	48
Dinner Casserole	48
Friendly Fish in a Sleeping Bag	49
Pork Chop Pot	49
Impossible Cheeseburger Pie	50
Easy Pizza	51
Sweet and Sour	51
Stove Top or Open Fire	
Camp Fire Lasagna	52
Beefaroni	52
Fireside Hodge Podge	53
Meal in a Pan	53
Sweet and Sour Ham / Pork / Bologna / Whatever	54
Meat Balls	54
Cheese Meatballs with Noodles	55
One Pot Spaghetti	56
Sloppy Joes for a Crowd	56
Chili	57
Camp Chili	57
Mexican Sloppy Joes	58
Pita Tacos	58
Patrol Stew	59
Friendship Stew	59
Hamburger Chop Suey	60
Corned Beef Hash	60
Coals or Charcoal	
Coffee Can Casserole	61

Shish Kebobs	62
Shishkabobs	62
Dinner on a Stick	63
Shish Kabobs	63
Steak Sandwiches	64
Burger Pockets	64
Hot Diggety Dogs	64

Tin Can Stoves

Festival Eggs	65
Quesodilla	65

Foil Cooking

Tin Foil Pizzas	66
Ham Mop-Ups	66
Pork Chops with Apple Slices	67
Pork Chop Foil Dinner	67
Chicken Dinner	68
Chicken-Corn-Carrot Dinner	68
Foil Dinner	69
Hamburger Dinner	70
Pocket Stew	70
Down South	71
L'il Abner	71
Chicken Deluxe	71
Fish Delish	71
Stewriffic	71
Ribbits	72
B.B.Q. Corn	72

No Utensils

Roast in Hot Coals	73
--------------------	----

Novelty

Hot Pot	74
---------	----

VEGETABLES

Tin Can Potatoes	75
Stuffed Potatoes	75
Potatoes	76
Rice and Consomme	76
Mixed-Up Neeps	77

HAY BOX STEW

- Cooking method: Hay box
- Preparation time: 1 hour
- Cooking time: 6 hours plus
- Servings: 24
- Special equipment: 2 hay boxes, each containing an 8-quart pot
- Ingredients: 4½ lbs (2 kg or 8 cups) stew beef, cut into ¾" squares
5½ lbs (2.5 kg or 16 cups) potatoes
3½ lbs (1.5 kg or 10 cups) carrots
2 lbs (800 g or 8 cups) celery
2 large onions
2 tbsp Worcestershire sauce
3 tsp salt
½ tsp pepper
20 - 22 cups water
2 - 3 tbsp oil
Instant potatoes or flour

Use 2 heavy 8-quart pots. Divide ingredients in half and do each pot separately.

Heat pot and add oil. Add meat (*do not flour meat*) and brown well on all sides. Add oil as needed. After browning, add some hot water slowly, then add the rest of the ingredients in any order. Add rest of water so meat is completely covered. Must be 2" space left at top of pot. Place lid on and heat to boiling. Boil 20 minutes. Stir occasionally.

Put pots into prepared boxes. Leave at least 6 hours. An hour before eating, check to see if stew is almost cooked. If it is still hot cover again. If it has cooled considerably, it will have to be finished on the stove. 15 minutes before eating, remove pot from box and put on stove. Bring to boil and simmer at least five minutes. Check for taste *now*. Do not over-season in pot but leave to individual taste. If thickening is needed, add a little flour and water and cook, or add a little instant potato (add only a little at a time, as it will really thicken in a hurry).

Comments: A small amount of turnip may be added, but only a little as it sweetens the stew too much or, depending on the turnip, will make it bitter.

2 cups of frozen peas may be added. If canned peas are used, add at the simmering time before serving. Any beef may be used; stew meat is already cut into pieces too large for this use, and contains fat and other undesirables. A large roast can be bought on sale with less waste and this can be cheaper. This stew recipe may be adjusted to any size. A good guide for quantities per person is ¼ lb meat, 1 medium potato, 1 medium carrot, and ½ to ¾ stalk of celery.

Directions for making a hay box can be found on page 5 in the Cooking Methods section.

Alice Filipchuk
Edmonton

SWEET AND SOUR PORK AND VEGGIES

- Cooking method:** Hay Box
- Cooking time:** 20 minutes plus all day in hay box
- Servings:** 8 - 10 depending on amount of veggies
- Ingredients:** 3 - 4 lb pork roast cut in $\frac{1}{2}$ - $\frac{3}{4}$ " cubes
- Sauce: 3 tbsp cornstarch in $\frac{1}{2}$ cup water
 - $\frac{1}{2}$ cup vinegar
 - $\frac{1}{2}$ cup sugar
 - 1 tbsp soy sauce
 - juice from 1 can pineapple (save fruit)
- 2 - 3 large onions, chopped lengthwise
1 medium head broccoli, stalk in 2" strips
1 green pepper, cut in strips
8 - 10 stalks celery, cut diagonally
8 - 10 carrots, sliced diagonally

Brown pork in a large pot. Bring sauce to a boil in separate pot and cook for 5 minutes. Add to meat and boil. Add onion, broccoli stalk, green pepper, celery, and pineapple. Bring to a boil and cook for 10 - 15 minutes. Add broccoli head for last 5 minutes. Cover pot and place in hay box.

Marlace Susut
Parkland



SATE AJAM

- Cooking method:** Reflector Oven
- Preparation time:** De-boning and placing on skewers - 10 minutes
Marinating - 30 minutes (can be done ahead of time)
- Cooking time:** Approximately 10 minutes
- Servings:** Pathfinders and up - 1 chicken breast
Brownies and Guides - ½ chicken breast
- Equipment:** Bamboo skewers, wire rack covered with foil
2 racks or 2 pieces of cardboard covered with foil, shiny side out
4 corner stones
- Ingredients:** Chicken breast (or ½ as noted) per person
Marinade for 6: ¼ cup soy sauce
1 tbsp oil
2 tsp brown sugar
½ tsp fresh ginger grated (or ¼ tsp powdered ginger)
1 garlic clove, minced

De-bone breast by inserting thumbs between meat and bone and gently push meat off bone. Tear away skin. Slice chicken into ½" slices the length of the breast. Place slices on water-soaked skewers. Do not crowd meat. Mix marinade in a plastic container by shaking. Layer chicken in sauce and refrigerate in refrigerator, cooler, or larder for 30 minutes or longer. Place chicken on foiled rack over hot coals and set up foil covered racks or cardboard as shown in diagram. Cook for 10 minutes or until chicken is opaque. Serve with rice and salad.

Celeste Pryde
Peace River

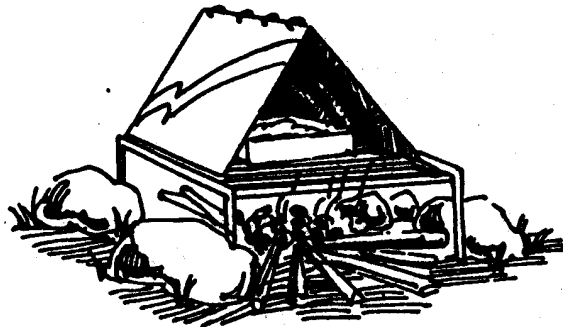

CABBAGE BREAD

Preparation time: 30 minutes

Cooking time: 30 minutes

Servings: 8

Ingredients: 1 pound hamburger
1 medium onion
½ of 5 - 6" cabbage, shredded coarsely
1 loaf frozen bread dough, or your own
½ tsp salt
1/8 - 1/4 tsp pepper

Let bread thaw. Fry hamburger until brown; add onions, salt, pepper. Add cabbage and cook slightly. Place dough on floured area and roll into strip about 6" x 30" or more. Cut into 8 equal strips. Spoon mixture into centre of each piece of dough. Pull sides up and seal together, pinching well. Place on cookie sheet and bake 20 minutes. Remove and brush with milk, return to oven for another 10 minutes (brushing with milk is not necessary but makes a softer crust).

May be eaten hot or cold.

Alice Filipchuk
Edmonton

DINNER CASSEROLE

Cooking method: Box oven or oven

Preparation time: 15 minutes

Cooking time: 2½ - 3 hours

Servings: 6

Ingredients: 14 pork sausages
6 medium potatoes, quartered
6 medium carrots, quartered
1 onion, chopped
1 can mushroom soup

In a baking dish, layer sausage, potatoes, carrots, and onions (or just dump these in and mix). Combine soup with ½ can of water and pour over vegetables and meat. Cover and bake.

Recipe can be prepared by any age, even Brownies, with help.

Alice Filipchuk
Edmonton

FRIENDLY FISH IN A SLEEPING BAG

Cooking method: Oven, 375° F
Cooking time: 45 minutes
Servings: 12
Ingredients: 1 can Pillsbury Crescent Dinner Rolls
8 frozen fish sticks
Catsup and olives for garnish

Unroll dough into long rectangle. Press diagonal perforations to seal. Cut the dough into rectangles as shown.

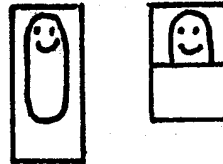
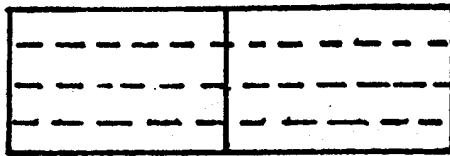

Place a fish stick on one end of rectangle; fold remaining dough so that it covers about one half of the fish stick. Press edges to seal. Place on ungreased cookie sheet. Bake at 375° until golden. If desired, use catsup to make faces and olives to make "hats". Serve with tartar sauce or cheez whiz if desired.

Recipe source: Pillsbury Activity Calendar 1983

Karen Edwards
Calgary

PORK CHOP POT

Cooking method: Oven, 350° F
Cooking time: 45 minutes
Servings: 4 (or 12, or 40)
Ingredients: 4 (12, 40) pork chops
1 (2, 8) cans tomato soup
½ (2, 6) cans water
1 tsp (2 tsp, 2 tbsp) Worcestershire sauce
4 - 6 (12 - 16, 40 - 60) small potatoes, quartered
4 (12, 40) small carrots, sliced

Brown chops, a few at a time, and remove to large roaster. Add potatoes and carrots. Mix soup, water, salt, and Worcestershire sauce and pour over the meat and vegetables, tossing to coat. Cover and bake at 350° for 45 minutes to one hour. Watch liquid.

Glen Allan District
Edmonton

IMPOSSIBLE CHEESEBURGER PIE

Cooking method: Oven, 400° F

Cooking time: 35 minutes

Servings: 6

Ingredients:

- 1 lb ground beef
- 1½ cups copped onion
- ½ tsp salt
- ¼ tsp pepper
- ¾ cup Bisquick baking mix
- 3 eggs
- 2 tomatoes
- 1 cup grated cheddar cheese

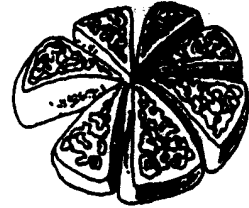

Grease 10" pie plate (1½" deep). Brown beef and onion; drain. Stir in salt and pepper. Spread in plate. Beat milk, baking mix, and eggs until smooth and pour into plate. Bake 25 minutes. Top with tomatoes, sprinkle with cheese. Bake until knife inserted comes out clean (5 - 8 minutes). Cool 5 minutes.

Betty Evans
Edmonton

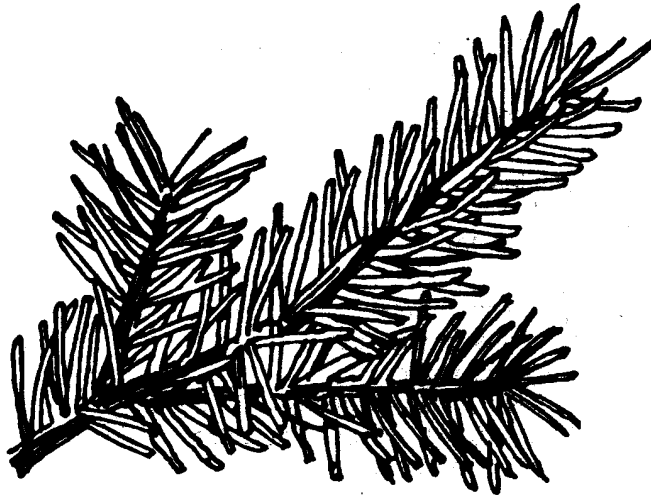

EASY PIZZA

Cooking method: Oven 450° F
Cooking time: 10 - 12 minutes
Servings: 2 - 6 (depending on appetite)

Ingredients:

<i>Crust</i>	<i>Sauce</i>
1½ cups flour	1 6oz can tomato paste
1 tbsp baking powder	½ tsp garlic salt
½ tsp salt	¼ tsp onion flakes
¼ cup oil	½ tsp oregano
½ cup milk	¼ tsp salt

Toppings A choice of bacon, salami, wieners, mushrooms, sardines, olives, pineapple, cheese, etc.

Mix flour, baking powder and salt. Make a well in centre, and add oil and milk. Mix until smooth. Knead ten times on a lightly floured board. Roll ¼" thick and place on a pizza pan. Brush with oil. Sprinkle with mozzarella cheese. Mix sauce and spread on crust. Add desired toppings. Sprinkle with grated parmesan cheese and bake.

Eleanor Grundberg
Edmonton

SWEET AND SOUR

Cooking method: Oven, 350° F
Cooking time: 2 hours
Servings: 40

Ingredients: Meat: 40 - 60 pork chops
OR 40 - 80 small chicken pieces
OR 20 lbs pork button bones
OR 10 lbs round steak, cut in strips

Sauce: 10 envelopes Lipton onion and mushroom soup mix
2½ cups vinegar
2½ cups brown sugar
1¼ cups bottled chili sauce or barbecue sauce
2 cups water
¼ cup corn starch

Mix the sauce ingredients in a bowl. Pour over raw meat in a large roaster, stirring to coat. Seal roaster with aluminum foil to prevent steam from escaping. Bake at 350° for 1½ hours. Remove roaster from oven. Drain or skim off fat. Mix water and corn starch, and stir into roaster, mixing carefully to ensure all the corn starch is well stirred in. Cover tightly and return to oven for another half hour. This may be made in two roasters, if the amount of meat is such that you think 2 hours of cooking time will not penetrate through one roaster, OR cooking time and/or oven temperature may be increased.

Variation: Do not thicken with cornstarch. Add celery, diagonally cut carrots, peapods, red and green peppers and mushrooms to roaster. Cook for ½ to 1 hour after addition of vegetables.

Glen Allan District
Edmonton

CAMP FIRE LASAGNA

Cooking method: Stove top or open fire

Cooking time: 20 - 30 minutes

Servings: 4

Ingredients:

- 1 lb ground beef
- 1 pkg onion soup mix
- 1 tsp oregano (Italian seasoning)
- 1 28 oz can tomatoes
- 2 cups water
- 2 cups uncooked medium macaroni (spirals are nice)
- 1/3 cup grated parmesan cheese
- Sliced mozzarella

Brown beef, drain. Add onion soup mix, oregano, tomatoes, water. Bring to a boil and stir in macaroni. Cook covered until macaroni is tender (20 - 30 minutes). Stir in parmesan cheese and top with mozzarella to serve.

Carol Peters
Edmonton

BEEFARONI

Cooking method: Stove top or fire

Cooking time: 15 - 20 minutes

Servings: 12 (can be increased)

Ingredients:

- 3 packages macaroni and cheese
- 1 lb ground beef (medium or lean)
- 1 large can spaghetti sauce
- 1 onion

Brown beef and onions in pan, then add spaghetti sauce. Heat through and remove from heat. Cook macaroni and cheese according to instructions. Add beef/sauce, mix gently, and reheat. Sauce can be cooked ahead of camp and frozen.

Girls can cook the macaroni over wood fires then add sauce.



Pat Scheepers
Edmonton

FIRESIDE HODGE-PODGE

Cooking method: Dutch oven, coals, stove top

Cooking time: 30 minutes

Servings: 12 - 15

Ingredients

- 2 lb ground beef
- 2 medium onions
- 4 Italian sausages
- 2 14 oz cans pork and beans
- 2 pkgs frozen or canned lima beans
- 8 wieners
- 3 cans whole tomatoes
- 1 cup brown sugar
- 3 tsp soy sauce
- ½ tsp oregano
- ½ cup catsup
- ½ cup apricot jam

Brown ground beef, drain. Add all ingredients except pork and beans. Drain juice off one can. Add both cans to other ingredients. Cook in Dutch oven over coals. Stir occasionally to keep from sticking.

M. J. Chambres
Montana

MEAL-IN-A-PAN

Cooking method: Stove top or fire

Preparation time: 20 minutes

Cooking time: 30 minutes

Servings: 6 (500ml serving)

Ingredients:

- 500 grams hamburger
- 175 ml diced onions
- 200 ml sliced celery
- 500 - 700 mg cooked macaroni
- 1 284 ml can cheddar cheese soup, diluted with ½ - ¾ cans water
- 150 ml green pepper, chopped (optional)
- 1 284 ml can mushrooms (optional)

Brown hamburger, celery, and onions. Drain well. Mix all ingredients together and heat until hot. Could be prepared at home and reheated at camp.

Karen Edwards
Calgary

SWEET AND SOUR HAM / PORK / BOLOGNA / OR WHATEVER

- Cooking method:** Stove top, lightweight stove, fire
- Cooking time:** 5 minutes
- Servings:** 4
- Ingredients:**
- 1 12 oz can ham or other canned meat or bologna, diced
 - 1 14 oz pineapple chunks, drain and reserve juice
 - green pepper
 - onions and/or celery, your choice, chopped
 - 1 pkg sweet 'n sour mix (choose brand which does not require addition of vinegar, such as Club House.)
 - 1 cup minute rice

In pot with lid, prepare minute rice according to directions and set aside. In medium-sized pot, mix sauce according to package directions and add chopped ingredients plus pineapple. If more liquid is needed, add pineapple juice. Heat thoroughly (about 5 minutes) and serve over rice.

- Variations:**
- Noodles instead of rice.
 - Almost any ingredient can be replaced with one of your choice.

Margaret Campbell
Edmonton

MEATBALLS

- Cooking method:** Oven (450° F) and stove top
- Preparation time:** 15 minutes (for an adult)
- Cooking time:** 45 - 50 minutes
- Servings:** 6 - 12 depending on age group
- Brownies:** 2 meatballs per serving
Guides: 3 per serving
Hearty eaters: 4 per serving
- Ingredients:**
- 1 lb hamburger
 - 2 tbsp chopped parsley
 - 1/8 tsp garlic salt
 - 1/2 tsp salt
 - green pepper (optional)
 - pepper - few shakes
 - 1 cup fine bread crumbs, fresh or dry
 - 1 tsp Worcestershire sauce
 - 1 tsp basil
 - 3 tbsp onion, finely chopped
 - 3 eggs
 - flour, water, 19oz can spaghetti sauce or your own

... continued

MEATBALLS continued

Combine all ingredients down to, and including, eggs in a bowl and mix well. Form into balls about 1¼" in size. Roll in flour and place in shallow pan in oven. Bake 15 minutes, turn meatballs with tongs, and bake another 15 minutes or until well browned. In sauce pan on top of stove, mix spaghetti sauce with ½ cup water and heat*. Add meatballs and cook for 15 - 20 minutes.

* If freezing, do not heat sauce; just pour it over meatballs. Make sure the meatballs are covered with liquid or they will dry out. Add more water if needed. This extra liquid is needed to reheat. Use shallow pan to freeze them in and they will heat up without being over stirred and ending up hash.

Serve with spaghetti or rice.

Alice Filipchuk
Edmonton

CHEESE MEATBALLS WITH NOODLES

Cooking method: Stove top

Cooking time: 25 minutes

Ingredients:

- A. 1 egg
½ tsp nutmeg
1¼ tsp salt
¼ tsp pepper
1 tbsp finely chopped parsley
1½ lbs ground beef
1/ cup dry bread crumbs
6 oz Swiss cheese, cut in ½" cubes
- B. 3 tbsp salad oil
3 medium onions, chopped
1 48 oz can tomato juice
8 oz uncooked medium egg noodles
¼ tsp pepper
¼ tsp thyme

Mix all the ingredients except cheese from "A" well; roll 2 tablespoons of mixture around each cheese cube. Heat oil in a large 4-quart pot. Brown half the meatballs at a time, set aside. Saute the onions in the dripping until golden. Add tomato juice to pot and bring to a boil. Slowly add the noodles so the liquid continues to boil. Stir in the meatballs, pepper and thyme. Cover and simmer 10 minutes, stirring occasionally.

Recipe source: *Canadian Guide*, May-June 1978, B.C. Camping Committee

Glen Allan District
Edmonton

Medium Noodles



ONE POT SPAGHETTI

- Cooking method:** Stove top
- Cooking time:** 25 minutes
- Servings:** 4 - 6, recipe may easily doubled
- Ingredients:**
- 1 lb ground beef
 - ½ cup chopped onions
 - 1 8 oz can tomato sauce
 - 1 15 oz jar spaghetti sauce
 - salt
 - dash sugar
 - 2 cups water
 - 8 oz spaghetti, or any pasta (except noodles)



Brown the beef in a Dutch oven. Drain off the fat. Add the onion, tomato sauce, spaghetti sauce, salt, sugar, and water and mix well. Add uncooked spaghetti. Bring to a boil, stirring occasionally. Reduce the heat, cover and simmer for 15 minutes. Stir again before serving. Sprinkle with parmesan cheese.

Glen Allan District
Edmonton

SLOPPY JOES FOR A CROWD

- Cooking method:** Stove top
- Cooking time:** 15 - 25 minutes
- Servings:** 10 or multiples of 10
- Ingredients:**
- (for 20)
 - 1½ lb ground beef
 - 1 medium chopped onion
 - 1 cup chopped celery
 - 1 tbsp chili powder
 - 2 10 oz cans tomato soup
 - water, ½ cup or more
 - 10 hamburger buns

Brown meat well; add vegetables and chili powder. Cook until tender. Add soup and water. Continue to cook to blend flavours, stirring occasionally. Hold in low oven or away from flame of campfire until needed. Beans may be added to this, but I usually serve them on the side.

Bertha Ashby
Woodsmoke

CHILI

Cooking method: Stove top
Cooking time: 15 - 20 minutes
Servings: 5 - 6
Ingredients: ½ - 1 lb hamburger
1 medium onion, finely chopped
1 28 oz can beans with pork
1 19 oz can tomatoes
1 19 oz can kidney beans
salt and pepper to taste

Brown hamburger and onions. Drain well. Put all ingredients in large pot. Cook about 15-20 minutes

Julie Nielsen
Tamarac

CAMP CHILI

Cooking method: Stove top
Cooking time: 30 minutes
Servings: 15
Ingredients: 2 cups chopped celery
1 cup chopped onion
2 lbs hamburger
2 large cans tomatoes
2 cups mushroom pieces (or 2 cans, drained)
2 small cans tomato paste
2 tsp salt
1 tsp garlic powder
1 tsp oregano
¼ tsp pepper
½ cup brown sugar
3 level tsp chili powder
1 bottle chili sauce
2 tsp Worcestershire sauce
½ tsp tabasco
2 large cans kidney beans

Brown hamburger, celery, and onions. Drain fat. Add all other ingredients and simmer for about 30 minutes. Freeze in ice cream pails until camp. This recipe should make about one pail. Can be heated in large pot or over buddy burners. A quick meal for first night at camp, served on an open-faced bun with finger food. Two pails (about 30 cups) is sufficient for a camp of about 30.

Alice Filipchuk
Edmonton

MEXICAN SLOPPY JOES

- Cooking method:** Stove top
- Cooking time:** 25 minutes
- Servings:** 4 very hungry people or 8 less hungry
- Ingredients:**
- 1 lb ground beef
 - 1 onion, chopped fine
 - 1 green pepper, chopped fine
 - ½ tsp garlic powder
 - 1 tsp chili powder
 - ½ tsp cumin
 - salt and pepper to taste
 - 1 7½ oz can tomato sauce

Brown meat with onions and green pepper, drain. Add rest of ingredients and simmer 20 minutes.

Relishes to top: chopped tomatoes, grated cheese, and shredded lettuce.

This recipe makes enough filling for 8 pita pockets, or topping for 8 bags of taco chips.

At camp: Serve these as sandwiches in pita pockets.
The mixture can be made ahead and frozen.

On hike: Put mixture in thermos bottle; pour out into a bag of taco chips, using bag as a bowl. Have a nourishing, quick and easy to clean up, meal.

Sue Burrows
Calgary

PITA TACOS

Make up required quantity of Sloppy Joe hamburger for your crowd. Serve in half a small pita bread (6 - 7") rather than a taco shell. Have bowls filled with chopped lettuce, chopped onion, chopped tomato, grated cheese, sour cream, chopped avocado, and taco sauce. Each girl adds what she likes.

Allow 2 halves per person.

Glen Allan District
Edmonton

PATROL STEW

Cooking method: Buddy burner, open fire

Cooking time: 5 minutes

Servings: 4 - 6

Ingredients: 2 carrots, diced and cooked
3 potatoes, diced and cooked
Hamburger or stew meat, cooked
1 cup pork and beans
1 cup tomato juice
salt and pepper to taste

Have girls bring one item each, making sure it is wrapped and sanitary. Put in pan and heat on buddy burner.

Julie Nielsen
Tamarac

FRIENDSHIP STEW

Cooking method: Stove top or open fire

Have girls bring one can of their choice of stew. Remove labels. Open cans and mix in a large pot. Surprising how it really turns out.

Julie Nielsen
Tamarac

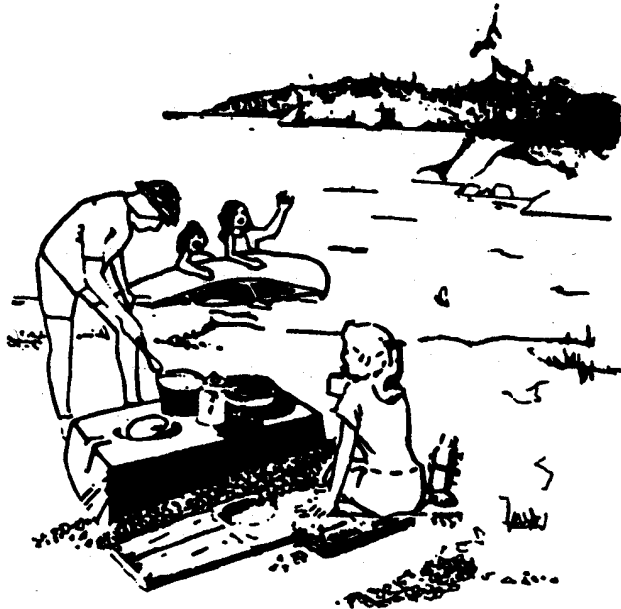

HAMBURGER CHOP SUEY

- Cooking method:** Stove top
- Servings:** 4 - 6 (may be expanded easily)
- Ingredients:**
- 1 lb hamburger
 - 1 onion, chopped
 - 2 - 3 stalks celery, chopped
 - 1 lb bean sprouts, fresh or canned
 - 1 can mushrooms
 - 1 beef bouillon cube
 - 1 cup hot water
 - 3 tbsp corn starch
 - ½ or ¼ cup soy sauce (to taste)

Brown meat; drain fat. Add celery and onions, brown. Drain mushrooms and save liquid. Add bean sprouts and mushrooms. Mix bouillon cube and hot water and add. Mix corn starch, mushroom liquid, and soy sauce. Add to mixture and stir until thick. Serve over Chinese noodles or rice.

Kathy Johnston
Edmonton

CORNERED BEEF HASH

- Cooking method:** Stove top
- Cooking time:** 20 - 30 minutes
- Servings:** 6 - 10
- Ingredients:**
- 2 - 3 tins corned beef (1 lb)
 - 2 tins green peas
 - 9 potatoes
 - butter and milk

Boil one medium-sized potato for each person. Drain and mash with a fork, adding one tablespoon butter and milk as needed. Break corned beef down into small pieces and add to potatoes, mixing thoroughly. If desired, the potato/corned beef mix can be moulded into patties and browned in a fry pan.

This recipe was tested at C.J. '77 Scout/Venturer Jamboree

Annette Jaenen
Edmonton

COFFEE CAN CASSEROLE

Cooking method: Coals or charcoal

Cooking time: 30 - 45 minutes

Servings: 4

Ingredients: 1 lb hamburger
4 small potatoes, thinly sliced
4 small carrots, thinly sliced
2 small onions, thinly sliced
salt and pepper

In empty 2 lb coffee can, place hamburger in bottom of can. Sprinkle with salt and pepper. Add the rest of the ingredients in the following sequence: a layer of onions, a layer of potatoes sprinkled with salt and pepper, and a layer of carrots sprinkled with salt and pepper. Cover the tin with aluminum foil.

Place in coals of fire for 40 - 45 minutes. Every 15 - 20 minutes, turn can around.

Gloria Klos
Edmonton

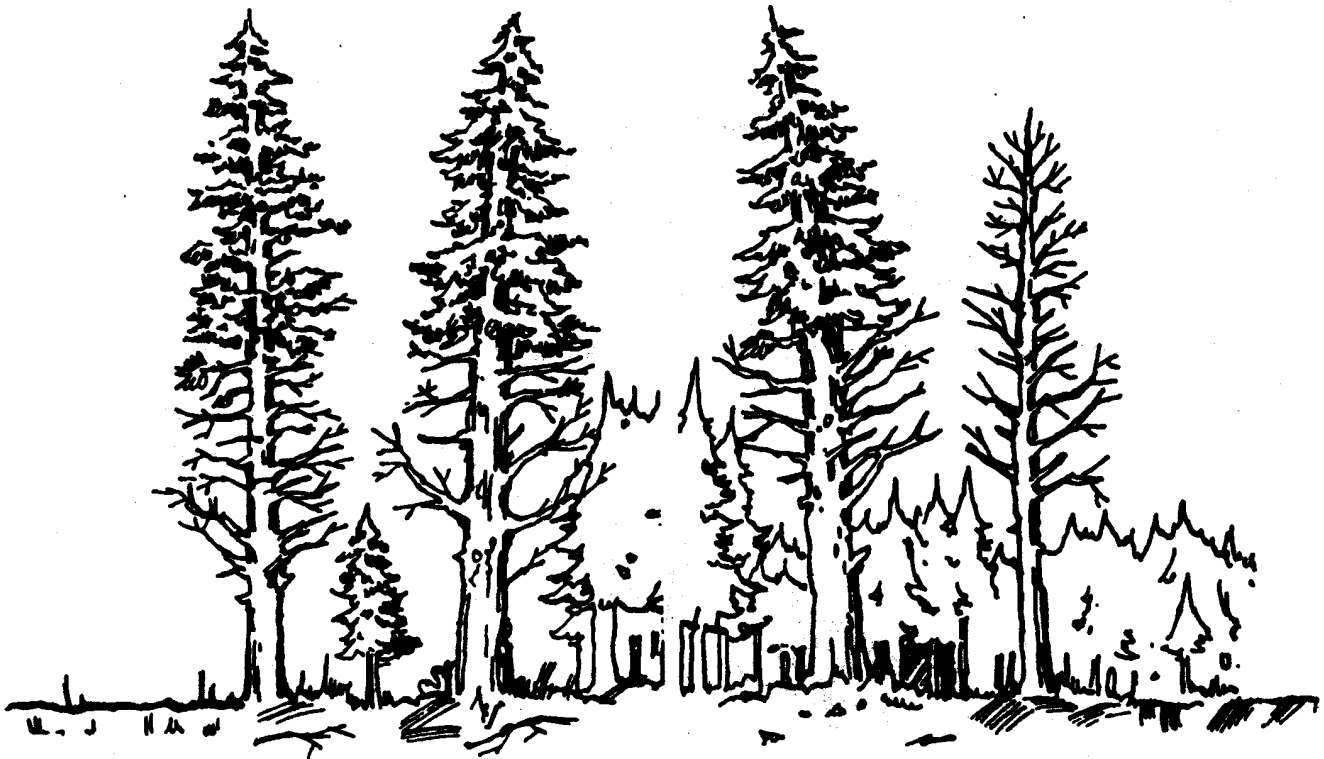

SHISH KEBOBS

- Cooking method:** Coals or charcoal
- Servings:** 24
- Equipment:** 1 wire cooking stick per person
- Ingredients:**
- 2 ready-to-serve pork cottage rolls
 - 2 packages wieners
 - 1 container cherry tomatoes
 - 1 bag frozen potato puffs, thawed
 - 3 cans pineapple tidbits
 - 1 bottle Kraft barbecue sauce
- Optional:** additional vegetables if they do not take too long to cook, such as zucchini, mushrooms, etc.

Build a light fire in advance, so it has burned down to coals. Briquettes may be used for additional heat.

Cut cottage rolls and wieners into chunks. Drain pineapple and save juice. Divide barbecue sauce into 4 bowls. Add small amount of pineapple juice to 2 bowls to taste. Put desired ingredients on wire stick. Brush with sauce. Cook over coals. Push off stick with knife to plate.

This is a favourite with the girls as *they* do all the cooking and there is little clean up. The shish kebobs were even cooked successfully on tin can stoves with buddy burners for fuel when a fire ban was in effect.

Irene Pettapiece
Edmonton

SHISKABOB

- Ingredients:**
- wiener, cut in 3
 - potato, cut in 4
 - small tomatoes
 - pineapple chunks or apple cubes

Alternate pieces on skewers. Cook over low coals. Can be brushed with barbecue sauce or catsup.

Julie Nielsen
Tamarac

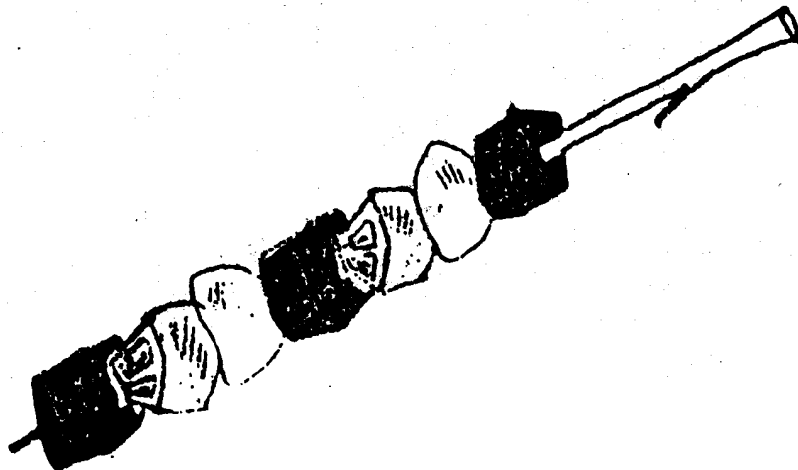

DINNER ON A STICK

- Cooking method:** Open fire, coals, charcoal
- Cooking time:** 10 - 20 minutes
- Servings:** 1
- Ingredients:** 4 oz meat (beef or lamb) cubed
assorted vegetables (pepper, cherry tomato, onion, mushrooms)
- Marinade:** ¼ cup oil
¼ cup vinegar
¼ tsp salt
dash of onion salt

Prepare marinade in a large screw top jar. Add meat and vegetables. Take jar along with you on your hike. At meal time, string everything on a green stick or skewer, alternating vegetables and meat. Grill over hot coals, turning often.

Pauline Stenzel
Tamarac

SHISH KABOBS

- Cooking method:** Open fire or charcoal
- Cooking time:** 10 - 15 minutes
- Servings:** 4
- Ingredients:** 1 lb chuck steak, 1½ cubes
4 sausages or ½ ring garlic or bologna sausage, 1" cubes
green peppers, cut into 1½" squares
12 small cherry tomatoes
8 small onions or onion quarters
barbecue sauce

Alternate meats and vegetables on sticks or skewers. Grill over coals 5 - 8 minutes. Brush with sauce and cook another 3 minutes. Yummy!

Gloria Klos
Edmonton

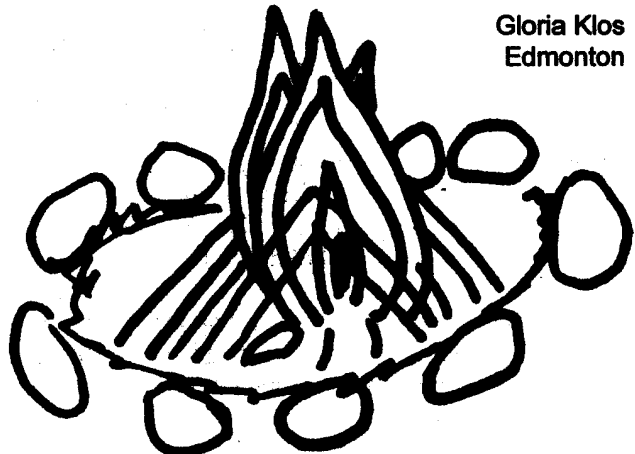

STEAK SANDWICHES

Cooking method: Charcoal or fire, using wire toaster

Servings: 4

Ingredients: 4 minute steaks
salt, pepper, garlic powder
barbecue sauce
4 kaiser rolls or bagels

Season the steaks with salt, pepper and garlic powder. Clamp in a wire toaster, and grill to desired doneness. Brush with barbecue sauce half way through. Serve in split buttered rolls.

BURGER POCKETS

Cooking method: Charcoal or fire, using wire toaster

Servings: 4

Ingredients: 1 lb ground beef
salt and pepper to taste
relishes to taste
4 hamburger buns

Make 8 flat hamburgers out of the ground beef. Season with salt and pepper. On top of 4 of them, each girl adds her own choice of relishes: 1 teaspoon each of mustard, catsup, relish, chopped dill pickle, finely chopped tomato, grated cheese, chopped onion . . .

Top these with the other 4 burgers and seal well by pressing around the edges. Lay these on the bottom half of a wire toaster and grill over the fire until the bottom is cooked. Then seal the top half of the wire toaster on, turn the burgers over and finish cooking (this prevents the raw burgers from breaking apart at first, before the meat is cooked). Remember whose is whose! Serve on buns.

Note: The wire toaster resembles 2 cake racks hinged together on a long handle.

Glen Allan District
Edmonton

HOT DIGGITY DOGS

Cooking method: Charcoal or fire, using wire toaster

Servings: 4

Ingredients: 8 hot dogs
8 slices bacon
8 thin strips cheese
8 hot dog buns

Cut a deep slit lengthwise in each hot dog. Insert strip of cheese in each. Wrap each hot dog in a bacon strip, winding the bacon around in a spiral. Secure each end with a toothpick. Clamp the 8 hot dogs in a wire toaster and roast over fire. Serve in buns (remove toothpicks).

Glen Allan District
Edmonton

FESTIVAL EGGS

Cooking method: Tin can stove with buddy burner, stove top or open fire

Cooking time: Sauce - 30 minutes
Eggs - 10 minutes

Servings: Adjustable

Ingredients: number of eggs each person wishes
1 oz cheese per person - cheddar, grated
1 tortilla per person
margarine

Sauce: 1 19 oz can tomatoes
½ green pepper, finely chopped
1 small onion, finely chopped
tabasco sauce to taste

For the sauce, saute onions and green pepper in margarine. Add tomatoes and simmer ½ hour. Add tabasco sauce to taste or leave to each individual to do so. Butter top of stove lightly. Put tortilla on stove and break egg on top of shell. Cover with lid or foil and leave until egg is cooked. Pour sauce over egg and sprinkle with cheese.

Celeste Pryde
Peace River

QUESODILLA

Cooking method: Tin can stove with buddy burner or 5 charcoal briquettes as heat source

Preparation time: 15 minutes - preheat stove for 5 minutes

Servings: one per 2 girls if snack
one per person if served as main course

Ingredients: 6 - 8 inch flour or corn tortillas, 2 per quesodilla
2 oz grated cheese (or other hard cheese)
Sauce, such as tomato or taco, and sour cream for dipping quesodillas

Separate frozen tortilla shells. Grate cheese and sprinkle evenly over one shell. Top with second shell. Carefully place on top of stove and heat until cheese has melted. Cut into pie wedges and serve with a dip if you wish.

Celeste Pryde
Peace River

TIN FOIL PIZZAS

Cooking method: Foil

Cooking time: 20 minutes

Servings: Individual

Ingredients: 2 cups Bisquick mix
½ cup water
dough for 16 pizzas in 4" foil pie pans
ready mix pizza sauce
toppings: ham, pineapple, green pepper, mushrooms, onions, pepperoni, etc.
mozzarella cheese

Grease pans well. Put in dough and spread to edges. Spread with approximately one tablespoon pizza sauce, and top with your choice of toppings. Put mozzarella cheese on top. Drugstore wrap in a "sandwich" of foil-wet newspaper-foil. Place on or near coals for approximately 20 minutes. *Do not* turn package upside down. Rotate for even cooking.

Variation: Use pita bread for crust. Also available are ready made shells from Bunmaster or other places.

Carol Buss
Edmonton

HAM MOP-UPS

Cooking method: Foil or box oven

Cooking time: 5 - 10 minutes

Servings: 10 (2 per person)

Ingredients: 3 cups cooked rice
1 cup chopped mushrooms
2 tbsp parsley
20 slices ham (thin)
1 10oz can cream of celery soup

Combine rice, mushrooms, and parsley. Put some on each ham slice. Add 1 teaspoon soup. Roll up ham slice and wrap with a "sandwich" of foil-damp newspaper-foil. Cook over fire 5" from flame, 3 minutes on each side. Serve with a salad.

Lorna Smith
Parkland

PORK CHOPS WITH APPLE SLICES

Cooking method: Foil
Cooking time: 40 minutes
Servings: 4
Ingredients: 4 pork chops
1 envelope mushroom gravy mix
1 or 2 apples

Core apple, slice into rings. On a sheet of foil, sprinkle some gravy mix. Place pork chops in a row, add remaining mix, and top with apple rings. Wrap securely in 2 wraps of foil. Cook, turning a few times on a grate of hot coals from a wood fire.

Bev Jaeger
Parkland

PORK CHOP FOIL DINNER

Cooking method: Foil
Cooking time: 20 - 30 minutes
Servings: 4
Ingredients: 4 pork chops or cutlets
1 cup minute rice
1 can cream of mushroom soup (or celery or tomato)
4 carrots, sliced or diced
1 onion, sliced
1 zucchini, sliced

Make a "sandwich" of two pieces of foil, 2' x 12-15" and wet paper towel or newspaper. Arrange ingredients on foil, shiny side in, and wrap securely. Cook over coals for 20 - 30 minutes, turning occasionally.

Mary McKenzie
Parkland

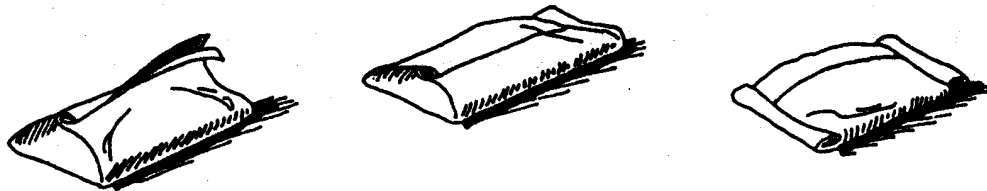

Drug Store Wrap

CHICKEN DINNER

Cooking method: Foil

Cooking time: 45 minutes

Servings: 4

Ingredients: 3 cups cooked rice
1 chicken, cut up (2½ - 3 lb, 8 pieces)
1 package dried onion soup mix
½ cup canned milk
4 tsp margarine

Have ready 4 pieces of heavy duty or double fold foil, 12" x 18". Put ¼ of rice in centre of foil. Sprinkle a tablespoon of onion soup mix. Put 2 chicken pieces on rice. Pour 2 tablespoons milk over the mixture. Sprinkle with 1 tablespoon onion soup mix and top with 1 teaspoon margarine. Drugstore wrap the dinner. Bake on grill over hot coals - 45 minutes. Turn packet over to cook evenly. Serve in foil.

Gloria Klos
Edmonton

CHICKEN-CORN-CARROT DINNER

Cooking method: Foil

Cooking time: 1½ hours

Servings: 4

Ingredients: 6 tbsp butter
2 1lb chicken breasts, halved
4 medium carrots, thinly sliced
4 ears of corn, halved
2 tbsp chopped chives
1 tsp salt
1/8 tsp garlic powder

Melt 2 tablespoons butter in a skillet. Add chicken and cook until browned. Place each chicken half on an 18" x 12" piece of heavy duty foil. Arrange ¼ of carrots and corn around each chicken half. Add the remaining butter, chives, salt and garlic powder to the butter in the skillet. Heat, stirring, until butter is melted. Pour ¼ over each chicken piece. Seal the foil pouches. Bake for 1½ hours.

Michelle DuChene
Edmonton

FOIL DINNER

- Cooking method: Foil
- Cooking time: 30 - 60 minutes
- Servings: 4
- Ingredients: $\frac{3}{4}$ cup rice, regular or minute
1 broiler-fryer chicken, quartered
2 tsp salt
1 10 oz can mushrooms
2 medium zucchini, sliced
1 green pepper, cut in strips
1 medium onion, thinly sliced
1 14oz can tomato sauce
 $\frac{1}{2}$ tsp oregano
 $\frac{1}{2}$ tsp basil
grated parmesan cheese

Place 3 tablespoons rice in centre of each of 4 - 12" squares of heavy duty foil. Sprinkle chicken with $\frac{1}{2}$ teaspoon salt and place on rice. Drain mushrooms and save $\frac{1}{4}$ cup of liquid. Divide mushrooms, zucchini, green pepper and onion into 4 equal portions and place over chicken. Mix together tomato sauce, $\frac{1}{4}$ cup mushroom liquid, oregano and basil. Spoon equally over chicken and vegetables. Seal foil tightly. Allow room for rice to expand. Place over coals and cook, turning occasionally for 30 - 60 minutes, depending on the thickness of the chicken. Sprinkle with parmesan cheese before serving.

Recipe source: *Canadian Guide*, May-June 1978.

Glen Allan District
Edmonton



Lambs-Quarters

HAMBURGER DINNER

Cooking method: Foil
Cooking time: 25 - 30 minutes
Servings: 1
Ingredients: 1 hamburger patty
1 potato, sliced
1 carrot, sliced
butter
onion soup mix

Lay section of foil out, shiny side up. Put hamburger, sliced potato, and sliced carrot on foil. Sprinkle with onion soup mix to taste. Add butter. Fold and seal foil packet. Cook over coals, 15 minutes each side.

Mami Staszko
Edmonton

POCKET STEW

Cooking method; Foil
Cooking time: 25 minutes
Servings: 1
Ingredients: 1 hamburger patty (¼ lb ground beef)
onion slice
potato slice
2 carrot sticks

Place patty on 12" square of heavy duty foil, double thickness. Top with slice of onion and slice of potato. Add 2 carrot sticks. Sprinkle with salt and pepper. Seal foil securely. Cook directly on hot coals 25 minutes, turning once. Eat stew from foil pocket.

Arlene Salzyn
Edmonton



A VARIETY OF FOIL DINNERS

Make sure your double-thickness of foil is large enough to enclose your meal. Place ingredients just off-centre and fold foil over, sealing tightly by folding three times. Cook on coals on a wood stove top or in a fire pit, turning 3 or 4 times.

Here are some combinations. Each makes one serving.

DOWN SOUTH 1 slice (1" thick) cooked ham

- Top with 2 tbsp orange marmalade OR 2 tbsp brown sugar and 1 tsp prepared mustard.

Add a pineapple ring stuck with a whole clove.
Add 2 pieces pared yam or sweet potato.

Cook: 1 hour

L'IL ABNER ½ small acorn squash, seeds removed

Top with 1 tbsp butter and 1 tbsp brown sugar.
Add 1 pork chop with the fat cut in 2 or 3 places.
Sprinkle with salt and pepper.

Cook: 1½ hours

CHICKEN DELUXE On the foil, arrange:

- 1 - 2 pieces chicken
- 1 peeled potato
- 1 tomato
- 1 small peeled onion
- 2 green pepper rings
- 2 - 4 mushrooms

Sprinkle with Worcestershire sauce, salt and pepper.
Sprinkle again with 2 tbsp minute rice and add 1 tbsp butter.

Cook: 1 - 1½ hours

FISH DELISH 1 halibut steak, frozen or thawed

Top with 2 tbsp chopped onion and 2 tbsp chopped green pepper.
Add 2 tbsp ketchup and a dash of garlic powder OR
sprinkle with lemon juice, Worcestershire sauce and dried dill.

Cook: 15 - 20 minutes

STEWRIFFIC 1/3 lb beef cut into cubes

Top with 2 tbsp bottled chili sauce mixed with 2 tsp flour.
Add 1 or 2 small peeled onions, a pared potato cut in quarters, a peeled and quartered carrot, and a sliced celery stalk. Sprinkle with salt and pepper.

Cook: 1 hour

... continued

A VARIETY OF FOIL DINNERS continued

RIBBITS

6 pork back or side ribs, in 2 rib sections

Top with ½ apple but cut into 4 pieces.

Add 1/3 cup drained sauerkraut.

Sprinkle with salt and pepper.

Top with a finely crushed ginger snap.

Cook 1 hour

Glen Allan District
Edmonton

B.B.Q. CORN

Cooking method: Coals or charcoal, foil

Cooking time: 25 minutes

Ingredients: 6 - 10 ears of corn
¼ cup margarine
½ tsp sugar
¼ tsp salt
¼ tsp paprika

Mix margarine, sugar, salt and paprika. Spread mixture on corn. Wrap loosely in foil, sealing carefully. Place 3" above glowing coals. Roast approximately 25 minutes, turning frequently.

Julie Nielsen
Tamarac



ROAST IN HOT COALS

Cooking method: No utensils, well prepared bed of coals

Preparation time: Fire bed - 1 hour
Roast - 10 minutes

Cooking time: 3 - 4 hours for 5 lb roast

Ingredients: 5 lb roast
water or milk to wet outside of roast
dry hot mustard
sea salt or other coarse salt

Build a good fire and feed well until the coals are red hot and in a pile twice the size of the roast. Wet the roast and cover with a thick layer of hot powdered mustard. Roll in salt until completely covered. Put roast in centre of coals and cover with remaining coals. When done, remove from coals and peel off outer layer; carve and serve.

Age group for preparation: Pathfinders and older
Age group for food appeal: Any age

Celeste Pryde
Peace River



Mustard

HOT POT

- Cooking method:** Novelty, using charcoal
- Preparation time:** 1 hour
- Cooking time:** Cooking is done as you eat, similar to fondue
- Age group for cooking:** Pathfinders or older
- Special equipment:** • Hot pot - available from oriental food stores

Ingredients: For 20 - 25
8 lbs chuck roast, lamb, pork, chicken
vegetables - celery, chinese cabbage, cabbage, canned baby corn,
mushrooms, bamboo shoots, water chestnuts, carrots, broccoli,
cauliflower
8 cups chicken broth (8 tsp chicken soup mix and 8 cups water)
1 lb fine noodles

Sauces: soy sauce, hot chinese sauce, plum sauce, mint sauce,
sweet and sour sauce, catsup and horseradish

Chop meats into 2" cubes. Cut vegetables in 2" chunks, spears, or other pleasing shapes. Put sauces into small bowls and arrange around hot pots. Heat broth and pour into bowl cavity of hot pot. Drop 8 burning coals into centre chamber of pot.

Each person then spears or picks up with chop sticks their choices and drops them into broth. The lid is then closed and food cooks while conversation takes place. Lid may be left open for slower cooking. When the major portion of the food has been used, the remainder and the noodles are put in the broth and the lid closed until noodles are soft, about 10 minutes. This is then used as a soup to end the meal. The sauces are used for dipping foods to the individual's own taste. Soup is drunk so no spoons are needed.

Celeste Pryde
Peace River



TIN CAN POTATOES

Cooking method:	Coals
Cooking time:	1 hour approximately
Servings:	any number
Ingredients and Equipment:	1 large can or 12 medium cans with wire handles foil heavy wax paper dirt or sand potatoes

Scrub potatoes well. Wrap each in wax paper and then in foil, shiny side in. Put a layer of dirt or sand in the bottom of the can, and then add potatoes. Depending on the size of the potatoes, you can get 6 or so in each can. The potatoes must not touch the side of the can. Pack sand or dirt around potatoes. Make sure all potatoes are covered with sand. Wet the sand and cover the can with foil. Place can on good bed of coals and heap coals up around the cans. Add water occasionally. When top potato is done, all will be done. Time: approximately 1 hour.

Lorna Smith
Parkland

STUFFED POTATOES

Cooking method:	Box oven (heated with 9 - 20 briquettes)
Cooking time:	Time to bake potato plus 10 minutes
Servings:	1 potato per person
Ingredients:	6 baked potatoes ¼ tsp salt 2 tsp butter chopped ham grated cheese



Preheat box oven. Scoop out middle of potatoes and mix potatoes with other ingredients. Restuff potatoes and wrap in foil and place in box oven. A good lunch served with carrot and celery sticks.

Lorna Smith
Parkland

POTATOES

Cooking method: Oven, 350° F
Cooking time: 45 minutes
Servings: 12
Ingredients: 5 lbs potatoes
6 oz cream cheese
1 cup dairy sour cream
2 tsp onion salt
dash of pepper
2 tbsp butter

Cook potatoes and mash; beat in remaining ingredients. Place in large greased casserole, dot with butter. If covered with plastic wrap, will keep 4 days in refrigerator. Heat 45 minutes at 350°.

Betty Evans
Edmonton

RICE AND CONSOMME

Cooking method: Stove top
Cooking time: 45 minutes
Servings: 24 (½ cup servings)
Ingredients: 1 cup butter
4 cups cooked rice
2 cups chopped onion
2 cups chopped green pepper
4 cans undiluted consomme
8 - 10 cups water

Melt butter in a very large kettle. Add the rice and stir until golden. Add the onion, green pepper, consomme, and 8 cups water. Mix well and cover tightly. Cook at a simmer for 45 minutes. Check after 25 minutes. If it appears too dry, add more water.

Glen Allan District
Edmonton

MIXED UP NEEDS

Cooking method: Stove top, open fire, or buddy burner

Servings: 6

Ingredients: 2 cups mashed turnip
1 cup mashed potatoes
2 tbsp butter
2 eggs, beaten
2 tbsp flour
2 tsp baking powder
½ cup bread crumbs
dash nutmeg
dash pepper
pinch salt
corn flake crumbs

Mix all above (with exception of corn flake crumbs) together. Make into patties and dip into corn flake crumbs. Fry until golden brown. Serve with any cold meat.

Lorna Smith
Parkland



DESSERTS AND SNACKS

	Page
Individual Fruit Cobblers	79
Half Hour Pudding	80
Half Hour Pudding II	80
Pudding	81
Dessert Dumplings	81
Brown Bears in an Apple Orchard	82
Pineapple Upside-Down Donuts	82
Campfire Fruit	83
Baked Apple	83
Peaches a la Site 3	84
Banana Boats	84
Peach Kebab	85
Chocolate Apple Rings	85
Hairy Beasts	85
Angels on Horseback	86
Banana Surprise	86
Chocolate Sauce	86
Ranger Fondue	87
Fruit Salad	88
Fruit Supreme	88

Carob Brownies	89
Apricot Bran Chews	89
Ice Cream a la Tin Can	90
Survival Ice Cream	91
Campers Fudge	92
Chocolate Noodle Drops	92
S'Mores	93
Chipmunks	93
Clowns	94
Ugly Mug	94
Edible Collage	95
Rocket Ships	95
Fruit Bowl	96
Fruit Cup	96
Dodo Bird's Nest	96
Snow Taffy	97
Chocolate Fudge	97
Popcorn Balls Camping Style	97
Popcorn Topping with a Difference	97
Finger Jello	98
Curry Snacks	98

INDIVIDUAL FRUIT COBLERS

Cooking method: Box oven

Cooking time: 30 - 40 minutes

Servings: 8 - 12

Equipment: Box oven
15 briquets of charcoal
tuna cans lined with foil

Ingredients: canned pie filling, apple, cherry, etc.
white or yellow cake mix OR bisquick

Grease foil-lined cans. Spoon 1 - 2 tablespoons of pie filling into each can. Pour on 2 - 3 tablespoons of prepared cake mix batter OR mix $\frac{1}{4}$ cup bisquick, 1 tablespoon butter, and 1 tablespoon hot water. Stir well and put on top of pie filling. Bake 30 - 40 minutes using 15 briquettes of charcoal.

Variations:

Spread a can of pie filling on bottom of cake pan. I like apple pie filling with cinnamon. Pour a prepared cake mix over pie filling. Chocolate with apple is good. Place in box oven for approximately 35 - 40 minutes. Serve with Cool Whip - great, and fattening too!

This is also very good made as an upside down pineapple cake. On bottom of cake pan, place pineapple slices, brown sugar, and pineapple juice. Cover with coffee cake mixture or regular cake mix. Gingerbread is excellent. Bake.

Phyllis Clow
Edmonton



HALF HOUR PUDDING

Cooking method: Oven, 350° F

Cooking time: 30 minutes

Servings: 4

Grease medium sized casserole.

In the casserole put: 2 cups boiling water
¾ cup brown sugar
1 tbsp butter

In a bowl mix: 1 egg
½ cup brown sugar

Add: 1 cup flour
2 tsp baking powder
½ tsp salt
1 cup raisins
½ cup milk
1 tbsp butter

Pour this mixture over sugar-water sauce in casserole. Bake for 30 minutes at 350°F.

Eleanor Grundberg
Edmonton

HALF HOUR PUDDING II

Cooking method: Oven or barbecue

Cooking time: 30 minutes

Servings: 6 - 8

Ingredients:	<i>Batter</i>	<i>Sauce</i>
	1/3 cup brown sugar	½ cup milk
	1 cup flour	1 cup- brown sugar
	2 tsp baking powder	2 cups boiling water
	1/8 tsp salt	½ tsp nutmeg
	½ cup raisins	1 tbsp butter

Mix batter and pour into a large juice can. Mix sauce separately and pour over batter. Do not mix sauce and batter together. Cover tin can with foil. Bake on grill over hot coals for about 25 - 30 minutes.

This can also be cooked in an 8" square cake pan in a 350° oven for 25 - 30 minutes.

Gloria Klos
Edmonton

PUDDING

Cooking method: Stove top
Preparation time: 20 minutes
Servings: 24
Ingredients: 3 pkg 3¼ oz or 92 g vanilla instant pudding
3 pkg butterscotch instant pudding
3 pkg chocolate instant pudding
3 pkg pistachio or caramel instant pudding
6 litres milk
2 250g containers whipping topping
24 clear plastic glasses

Mix pistachio or caramel pudding following package directions. Pour ¼ cup into each glass. Mix vanilla pudding and repeat. Repeat with butterscotch and chocolate puddings. At time of serving, put a small amount of whipped cream on each.

Mary McKenzie
Parkland

DESSERT DUMPLINGS

Cooking method: Stove top, fire
Cooking time: approximately 15 minutes
Servings: 4 or 5
Ingredients: ¼ cup flour
1½ tsp baking powder
¼ tsp salt
½ tsp soft margarine
1/8 cup milk
1 can of any kind of fruit (blueberry, raspberry, peaches, etc.)

Bring fruit to a boil. Mix other ingredients together and drop by teaspoonfuls into boiling fruit. Cook on low heat for approximately 15 minutes. Serve as is or with cream.

Julie Nielsen
Tamarac

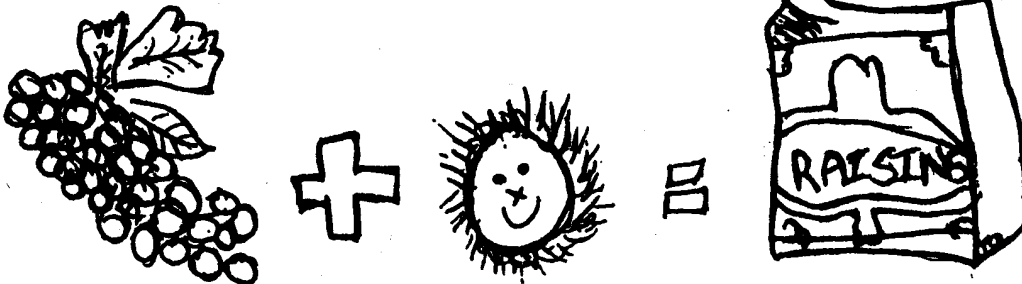

BROWN BEARS IN AN APPLE ORCHARD

Cooking method: Fire, stove top
Cooking time: 20 minutes
Servings: 6
Ingredients: 2 cans applesauce
1 pkg gingerbread mix
(follow directions for cookie mix)

Heat two cans of applesauce in deep pan. Mix package of gingerbread cake mix following directions for cookie mix. Shape gingerbread into small balls. Spread over top of hot applesauce. Cook over low fire for approximately 10 minutes uncovered and 10 minutes covered, or until gingerbread is done.

Phyllis Clow
Edmonton

PINEAPPLE UPSIDE-DOWN DONUTS

Cooking methods: Foil
Cooking time: 15 - 20 minutes
Servings: 1
Ingredients: 1 donut
1 pineapple slice
1 tsp brown sugar
½ tsp butter
1 cherry
miniature marshmallows (optional)

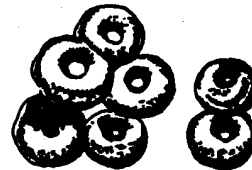

Cut the donut in half making a top and a bottom. Sandwich the pineapple in between the halves. Fill the centre with the brown sugar and butter. Top with cherry and marshmallows.

Wrap in foil and cook on grill above bed of hot coals until marshmallows are melted, approximately 15 - 20 minutes.

Note: Do not cook in coals as donut will burn.

Recipe source: Calgary Area "Let's Camp"

Bev Jaeger
Parkland

CAMPFIRE FRUIT

Cooking method: Foil, over coals
Cooking time: 10 - 15 minutes
Servings: 1
Ingredients: 1 pear, peeled and quartered
5 ml (1 tsp) honey
15 ml (1 tbsp) currants
15 ml (1 tbsp) slivered almonds
candied ginger or a dash of ginger



For each serving, place pear slices on a heavy duty foil (2 pieces with damp newspaper between). Drizzle fruit with honey and sprinkle with currants, almonds and ginger. Seal tightly and cook over coals.

Variations: Use the same method with other fruit combinations.

1. Orange segments, sliced bananas, coconuts, marshmallows, and a dash of lemon juice.
2. Peach halves, apricots, or raspberries with nutmeg and sugar.
3. Slit a whole banana lengthwise and fill with carob chips, walnuts and marshmallows.

Recipe Source: Marg's Campfire Cookery Kitchen!

Margaret Seel
Calgary

BAKED APPLE

Cooking method: Foil, Dutch oven, reflector oven or can oven
Cooking time: 45 minutes
Servings: 1
Ingredients: 1 apple
brown sugar
butter
cinnamon
marshmallows
raisins or nuts

Core the apple. Place combination of the above in the centre of the apple. Wrap in foil by bringing sides up and twisting the top. Cook slowly over the coals.

Marnie Staszko
Edmonton

PEACHES A LA SITE 3

Cooking method: Foil
Cooking time: few minutes
Servings: 1
Ingredients: canned peach halves
brown sugar and cinnamon

Fill cavity of peach with brown sugar and cinnamon. Wrap in foil and heat. If available, top with Cool Whip. Simple but delicious.

Cathy Beauvais
Edmonton

BANANA BOATS

Cooking method: Foil
Cooking time: 10 minutes
Servings: 1
For each: banana
miniature marshmallows
chocolate chips

Cut V-shaped wedge lengthwise in a firm, peeled banana. Place on a 18" x 6" piece of double thickness heavy-duty foil. Fill groove with cut-up or miniature marshmallows and chocolate chips. Wrap securely in foil and cook directly on medium coals 10 minutes.

Variations: coconut, brown sugar and pineapple

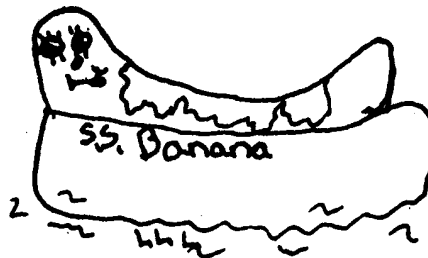

PEACH KEBOB

Cooking method: Coals or charcoal

Ingredients: 6 canned peach halves, drained
3 bananas, thickly sliced
2 apples, cored and thickly sliced
1 cup grapefruit juice
1 cup honey

Mix grapefruit juice and honey together. Marinate fruit in this mixture for a minimum of 30 minutes. Thread on skewers or green willow sticks. Barbecue on grill 3 - 5 minutes, basting with marinade.

Gloria Klos
Edmonton

CHOCOLATE APPLE RINGS

Cooking method: Foil

Servings: 3 - 5

Ingredients: 2 apples peeled, cored, and cut into $\frac{3}{4}$ " slices
 $\frac{1}{4}$ cup peanut butter
 $\frac{1}{4}$ cup chocolate sauce, bought or home made
1 tbsp butter or water (water will not burn)

Mix peanut butter and chocolate sauce together until blended. Spread each apple slice with mixture. Put 3 apple slices on a foil 'sandwich' (6" square). Sprinkle with water or dot with butter. Seal packet. Place packet on campfire coals 10 - 12 minutes, longer if coals are dying and shorter if fresh.

HAIRY BEASTS

Ingredients: 1 can sweetened condensed milk
 $\frac{1}{8}$ cup regular milk
1 loaf unsliced bread
1 cup coconut

Combine the two milks in a bowl. Remove crusts from bread and cut into cubes the size of a regular marshmallow. Dip bread cubes in milk mixture and then roll in coconut. Put on wiener stick and toast over hot coals.

Julie Nielsen
Tamarac

Variation: Cut a very firm pound cake into $1\frac{1}{2}$ " cubes. Allow 2 - 4 cubes per person. Treat as described above.

Variation: Glen Allan District
Edmonton

ANGELS ON HORSEBACK

Cooking method: Toasting on open fire

Servings: Allow 2 - 3 per person

Ingredients: 1 or 2 loaves French bread
coconut, medium length
Eagle Brand sweetened condensed milk



Remove crust from bread and cut into 1½" cubes. Dip cubes into condensed milk and roll in coconut.

Marlace Susut
Parkland

BANANA SURPRISE

Ingredients: ripe but firm bananas
melted chocolate or chocolate chips
one of coconut, finely chopped walnuts, or cake sprinkles

Cut banana in half, peel, and put on a popsicle stick. Dip banana into melted chocolate and roll in one of the coatings.

Marlace Susut
Parkland

CHOCOLATE SAUCE

Ingredients: ¼ cup cocoa
¾ cup sugar
1/8 tsp salt
¾ cup water
1 tsp vanilla

Mix all ingredients except vanilla and boil for 3 - 4 minutes. Add vanilla.

Makes 1¼ cups of sauce.

Marlace Susut
Parkland

RANGER FONDUE

Cooking method: Stove top, lightweight stove, fire

Preparation time: About 1 hour

Cooking time: 15 minutes

Servings: 10 - 15

Ingredients: 3 tbsp margarine or butter
3 pkg semi-sweet chocolate chips
1 4oz can evaporated milk
assorted fruits, nuts, marshmallows, red berries, jujubes, candies, etc.

Mix butter, milk, and chocolate in pot and melt. Cut fruit, etc. into bite size chunks for dipping. When fondue has melted, remove from heat, call everyone over with their forks, and dip away.

- Variations:**
1. Add flavouring to the fondue mix
 2. Use white chocolate
 3. Mix chips - 1 bag chocolate, 1 bag mint
 4. Replace chips with chocolate bars and "dippers" - can be left-over fruit, etc. making it a great dessert for the last night of a backpacking trip.

Note: The more chocolate or milk added, the more people can be served. Keep the proportions similar to those shown above.

Susan Ruzek
Calgary



FRUIT SALAD

Ingredients: 1 can crushed or chunk pineapple (for 8 - 10 servings)
fresh fruit cut into small pieces (bananas, apples, oranges, etc.)
maraschino cherries and juice (optional)

Put pineapple and juice in a large bowl. Add fruit and stir. This is a good way to use leftover fruit. The pineapple juice keeps the fruit from darkening so it can be prepared a couple of hours in advance. This recipe has been used successfully for breakfast and for lunch.

Irene Pettapiece
Edmonton

FRUIT SUPREME

Mix any fresh, canned, or leftover fruit with a few tablespoons of sour cream. Quantity depends on the amount of fruit used. Add some raisins and miniature marshmallows, sprinkle with coconut, and enjoy.

Kimberley Lindner
Edmonton

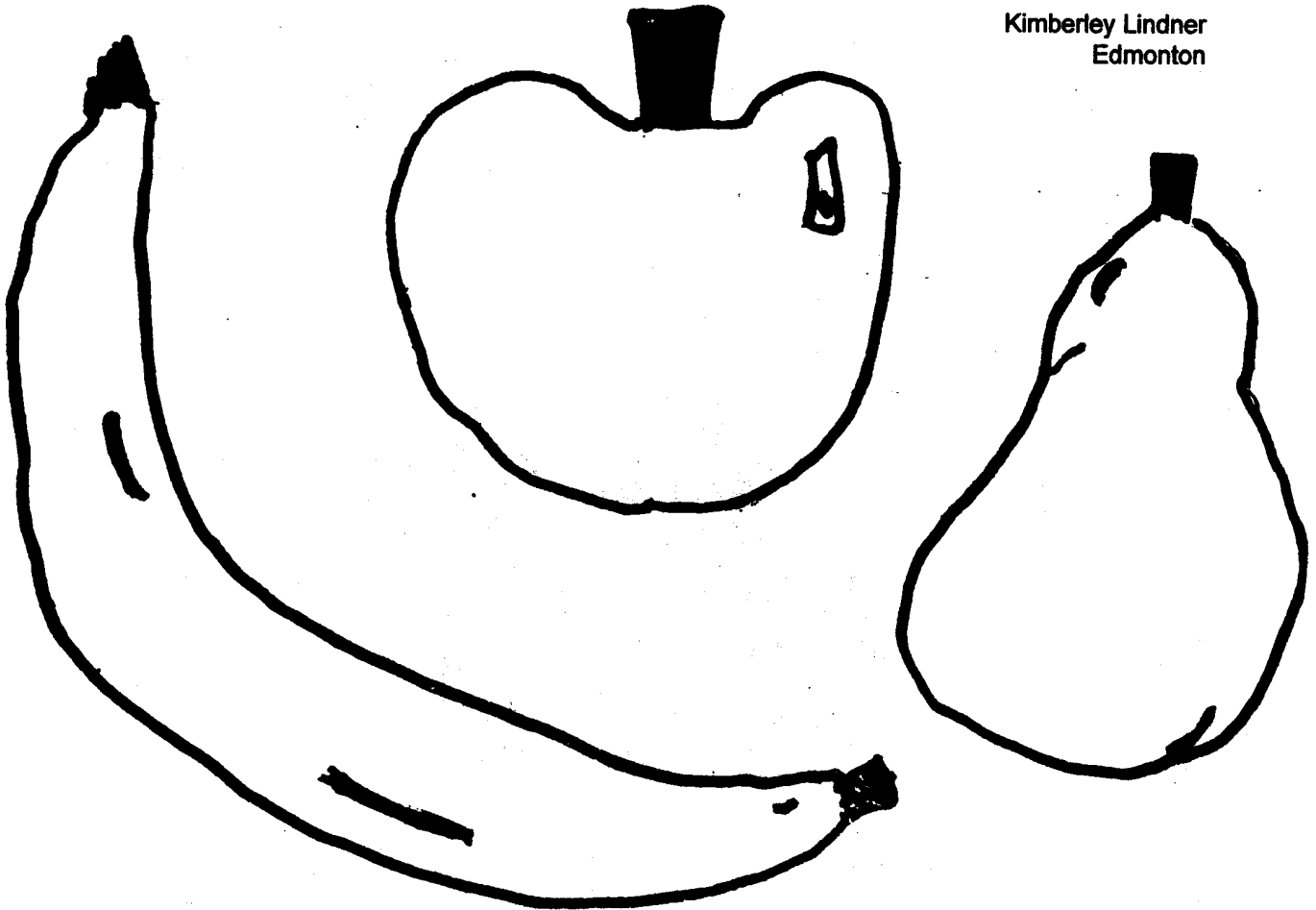

CAROB BROWNIES

Ingredients:

- ½ cup oil
- ½ cup honey
- 2 eggs
- ½ tsp salt
- 1 tsp vanilla
- 1/3 cup carob powder
- 2/3 cup whole wheat flour
- 2 tbsp milk powder
- 1 tsp baking powder
- 2/3 cup sunflower seeds
- ½ cup chopped walnuts

Cream oil and honey. Beat in eggs, salt, and vanilla. Mix together carob powder, whole wheat flour, milk powder, and baking powder. Stir into creamed mixture. Stir in seeds and walnuts.

Place in oiled baking pan. Bake at 325° for 20 - 25 minutes. Cool and cut.

Kay Quon
Edmonton

APRICOT BRAN CHEWS

Ingredients
and procedure:

- 1/3 cup whole bran cereal
- ¼ cup water - combine and set aside

- ¼ cup margarine
- ¼ cup firmly packed brown sugar - beat until creamy

- 1 egg - add and beat until fluffy

- ¼ cup honey
- 1 tsp vanilla - mix into above and then all in to bran

- 1 cup all purpose flour
- 1 cup quick cook rolled oats
- 1 tsp baking powder
- ¼ tsp each salt and baking soda
- ¼ cup chopped walnuts
- ¼ cup skim milk powder
- 1 cup finely chopped dried apricots - combine and add to above.

Drop by tablespoonfuls onto greased cookie sheet about 2" apart. Bake at 375° F for 10 minutes or until golden. Makes 3 - 4 dozen. Freezes well.

Kay Quon
Edmonton

ICE CREAM A LA TIN CAN

- Preparation time:** 5 minutes
- Cooking time:** 20 - 30 minutes
- Quantity:** about 3 cups
- Equipment:** 1 3 lb can with tight fitting lid (McGavin's Instant Mashed Potatoes is ideal)
- Supplies:**
- 1 1 lb tin can with tight fitting lid (coffee tin)
 - Rock salt
 - Ice
- Ingredients:**
- 1 cup milk
 - 1 cup whipping cream
 - ½ cup sugar
 - ½ tsp vanilla
 - nuts, chocolate chips, fruit, as desired

Put all ingredients into the 1 lb can and place cover on it. Place can with ingredients inside the 3 lb can. Pack larger can with crushed ice around the smaller can. Pour ¼ cup rock salt evenly over ice. Place lid on 3 lb can.

Roll can back and forth on the floor for 10 minutes. Open inner can and scrape side of can. Replace lid, add more ice and salt to outer can. Roll for 5 more minutes. Et voila! Ice Cream a la tin can.

The tin cans can be used for a terrific game of kick the can after the ice cream is eaten!

Recipe Source: Stevie Wood, Morin Heights, Quebec

Alternate recipe:

- 1 can sweetened condensed milk
- 1 - 2 cups milk
- nuts, chocolate chips, fruit, etc.

Follow above directions.

Note: If it is necessary to tape lid on cans use duct tape, electrical tape, or filament tape.

Susan Ruzek
Calgary



SURVIVAL ICE CREAM

- Preparation: 15 minutes
- "Cooking" time: 10 minutes
- Servings: 3 - 6 cups depending on snow
- Equipment: 2 mixing bowls
- Ingredients: 1 8 oz can evaporated milk
½ tsp vanilla (optional)
nuts, fruit, etc.
(Have found that almost thawed raspberries or strawberries work best)
- Clean snow

This ice cream is best made in the winter for obvious reasons.

Collect snow (clean) in a bowl.

Mix evaporated milk, vanilla, and fruit, etc. in the other bowl. Add snow to this mix until the desired consistency is reached. Serve.

For a different flavour, honey or brown sugar can be added to the milk before mixing.

Susan Ruzek
Calgary



CAMPER'S FUDGE

Ingredients: ½ cup margarine
 ¼ cup boiling water
 ½ cup cocoa
 ½ cup powdered milk
 1/8 tsp vanilla
 1 lb icing sugar

Melt margarine in boiling water. Add the rest of the ingredients. Spread on a plate and cool.

Makes 1½ lbs of calories!

Julie Nielsen
Tamarac

CHOCOLATE NOODLE DROPS

Melt a package of chocolate chips in a pot over low heat. Add chow mien noodles to melted chocolate. Cover cookie sheet with wax paper and drop spoonfuls of chocolate-coated noodles on the paper.

Place cookie sheet in a cool spot so that the drops will harden. Eat and enjoy!

Julie Nielsen
Tamarac

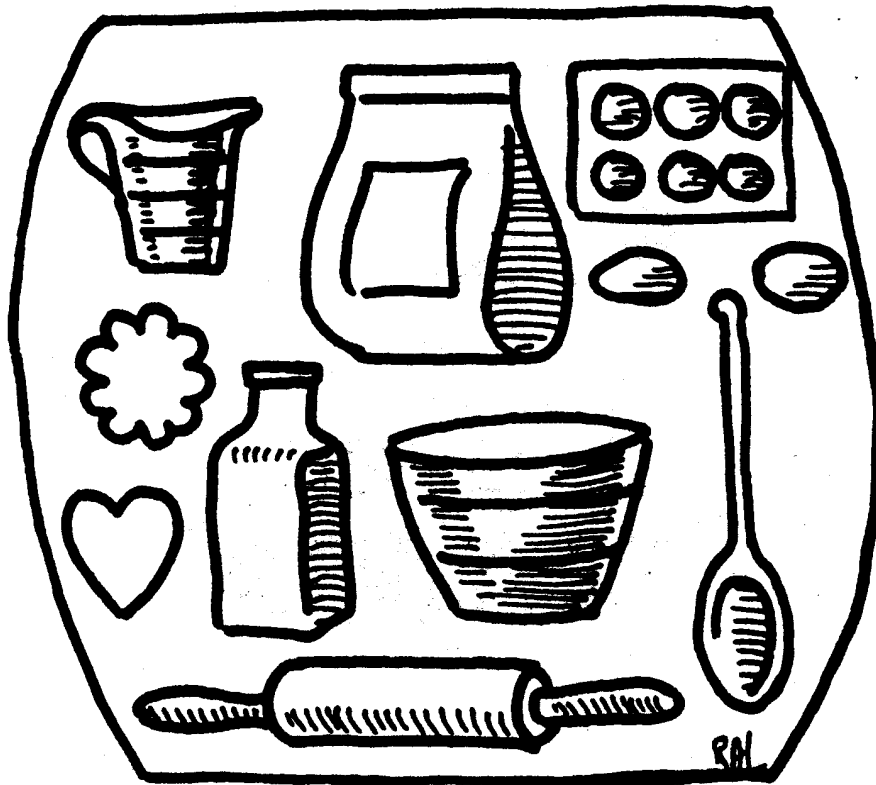

S'MORES

Cooking method: Foil

Cooking time: 5 minutes

S'Mores I: Place a marshmallow and a square from a milk chocolate bar between 2 graham wafer squares. Wrap in foil "sandwich". Place on hot coals and cook 5 - 10 minutes turning once or twice. The doublefoil wrapping allows the s'mores to heat without the crackers burning.

S'Mores II: Place a marshmallow between two milk chocolate digestive biscuits, with the chocolate on the inside. Wrap and cook as above.

Glen Allan District
Edmonton

S'Mores III: Toast marshmallows until well done; put between graham crackers along with 2 plain chocolate squares. You will see they are so good you will want s'more and s'more and s'more !!!

Julie Nielsen
Tamarac

CHIPMUNKS

Cooking method: Foil

Cooking time: 5 - 10 minutes

Split a small brownie square through the middle. Place an After-Eight mint (or any chocolate mint candy) in the middle. If the Brownie is iced, turn the icing to the inside. Wrap and cook as for S'Mores.

Glen Allan District
Edmonton

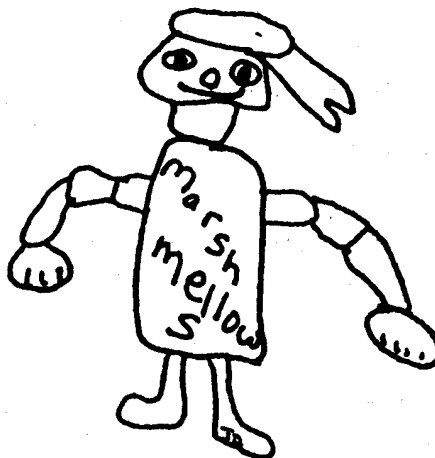

CLOWNS

- Preparation time:** 15 minutes in addition to time for jelly to set
- Servings:** 4 - 6 (1 package will make 4 - 6 servings depending on the size of glass used. Adjust for larger quantities).
- Ingredients:**
- 1 pkg lime-flavoured jelly powder
 - 2 cups boiling water
 - 1 cups cold water
 - pineapple rings
 - marshmallows
 - gumdrops

Dissolve jelly powder in boiling water. Add cold water. Pour into parfait, wine (or whatever shape you'd like) glasses. Chill until firm.

For clown collar, top each glass with serrated pineapple ring. Place large marshmallow on ring for head, outline eyes, nose, mouth, with toothpick dipped in food colouring. Attach gumdrop for hat with toothpicks.

Pat Ostapowich
Edmonton

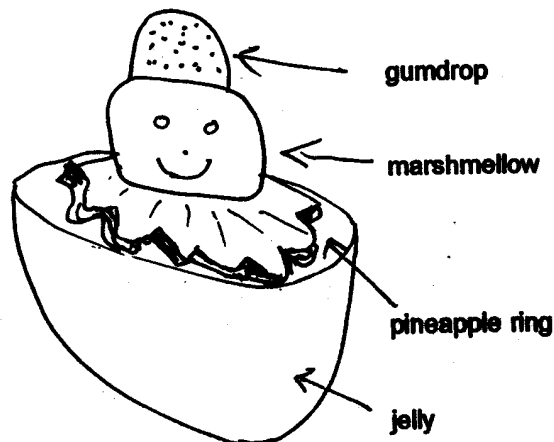

UGLY MUG

- Ingredients:**
- 1 pkg chocolate pudding
 - milk to mix (about 1 cup)
 - 1 tbsp peanut butter
 - 15 shelled peanuts

Put the peanut butter in a bowl. Add enough milk to make it runny. Stir in the pudding and beat with a fork. Pour the mixture into serving dishes. When set, make a face with the peanuts.

Julie Nielsen
Tamarac

EDIBLE COLLAGE

- Equipment:** paper plates, 1 per girl
plastic spoons, 1 per girl
- Ingredients:** honey
a variety of: miniature marshmallows
pretzels
corn ships
popcorn
raisins
flaked coconut
gum drops
cereal, etc.

Give each girl a paper plate, a spoon, and goodies. Spread a spoonful of honey on the plate to act as glue. Make patterns or pictures using a variety of goodies. When everyone is finished, admire then eat.

ROCKET SHIPS

- Servings:** 1
- Ingredients:** ½ banana
pineapple rings
whipped topping
nuts, cherries, coconut, chocolate chips, etc.

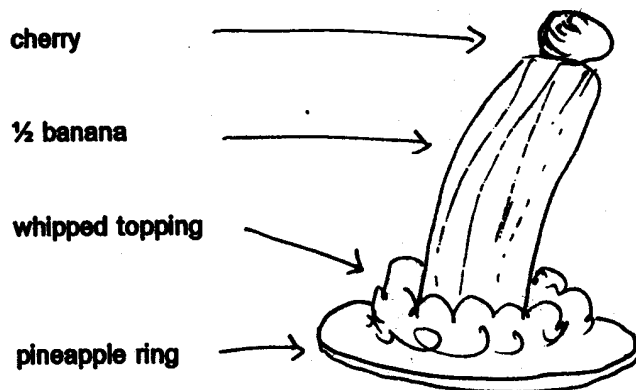

Attach banana to pineapple ring with whipped topping. It should stay put until eaten. Sprinkle with whatever else you like.

Brownies love this because they do their own decorating.

FRUIT BOWL

To prevent fruit from being wasted by girls (especially Brownies) unable to finish a whole piece, put out bowls of cut fruit for snacks. Cut bananas into 4 pieces, leaving the peel on! Cut oranges into quarters. Cut apples in half, scoop out the seeds with a quick twist of a melon baller, and cut each in half again. Set out the fruit mixed in bowls and watch it disappear!

Glen Allan District
Edmonton



FRUIT CUP

Use four or five varieties of fruit (e.g. melons, fresh pineapple, bananas, apple, pear, peaches, etc.) Pare and cut into large bite-size pieces. Use enough fruit so each girl has a paper cup full. Pathfinders have a challenge to make a paper cup (origami). In large bowls serve yogurt, sesame seeds, sunflower seeds, nuts, coconut, etc. and have girls choose two or three toppings each to add to their fruit.

This is a good way to use ripening fruit the girls might not like to eat separately.

Betty E. Quinn
Edmonton



DODO BIRD'S NESTS

Spread whole wheat crackers with softened cream cheese. Sprinkle on lots of alfalfa sprouts and top with a cherry tomato. Voila - Dodo Bird's Nest complete with the egg.

Betty E. Quinn
Edmonton

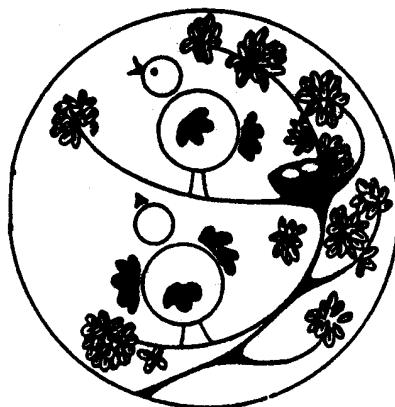

SNOW TAFFY

Cooking method: Stove top

Ingredients: 3 cups sugar
½ cup whipping cream
½ cup cereal cream

Bring ingredients to a boil to soft ball stage. Put clean snow on cookie sheet. Spoon taffy on the snow to set. This is a very rich candy, so a little goes a long way.

Julie Nielsen
Tamarac

CHOCOLATE FUDGE

Cooking method: Stove top

Ingredients: 2 cups sugar ½ cup flour
 ½ cup milk 1 tsp vanilla
 ½ cup margarine
 3 tbsp cocoa

Mix sugar, milk, margarine, and cocoa. Boil to soft ball stage. Remove from heat and blend in flour and vanilla. Put in buttered pan to cool.

Julie Nielsen
Tamarac

POPCORN BALLS CAMPING STYLE

Ingredients: 1 cup unpopped popcorn
 ¼ cup oil or margarine
 ¾ tsp salt
 ½ - 1 bag miniature marshmallows

Pop the corn in a little oil or margarine. Sprinkle salt on popcorn. Alternate layers of popcorn and marshmallows in a large roaster or frying pan with a lid. Heat slowly so the marshmallows are almost melted but not completely. Grease hands and roll into balls.

Julie Nielsen
Tamarac

POPCORN TOPPING WITH A DIFFERENCE

Ingredients: 2 tbsp margarine
 1 tbsp oil
 dash of garlic salt
 1/8 tsp dry mustard
 sprinkle of cayenne pepper

Melt margarine with oil. Add spices. Drizzle over popcorn.

Julie Nielsen
Tamarac

FINGER JELLO

Ingredients: 2 pkgs jelly powder
 2 pkgs unflavoured gelatin
 2 cups boiling water
 2 cups cold water

Dissolve gelatin with $\frac{1}{4}$ cup cold water. In another bowl dissolve jelly powder with boiling water. Stir until dissolved. Add gelatin mixture to jelly mix. Put on cookie sheet and let it set. Cut it into squares or shapes and serve.

Julie Nielsen
Tamarac

CURRY SNACKS

Cooking method: Stove top (make at home, take to camp)

Servings: 40 - $\frac{1}{2}$ cup servings

Ingredients: 1 cup butter or margarine
 2 - 4 tbsp curry powder
 1 tbsp cinnamon
 8 cups Shreddies
 4 cups pretzel sticks
 4 cups salted peanuts (or use soya nuts)
 2 cups whole almonds (or use Corn Pops cereal)
 2 cups raisins

Melt the butter in a large roasting pan. Stir in curry powder and cinnamon and cook for one minute. Add other ingredients and heat, tossing well, until heated through. Cool thoroughly.

Makes 20 cups.

Glen Allan District
Edmonton

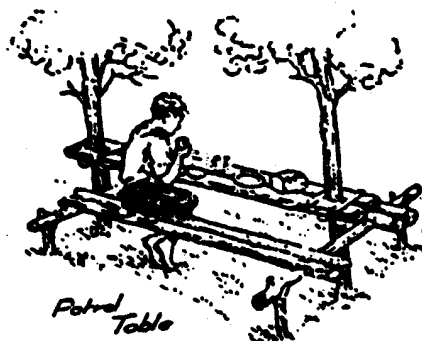

BEVERAGES

	Page
Hot Chocolate Mixes I, II, III, IV.	99
Friendship Tea I, II.	100
Mocha Drink	100
Mulled Apple Cider	100
Hot Drink Ideas	100
Cariboo	101
Skier's Tea	101
Apple-Orange Refresher	102
Pineapple Punch	102
Popsicle Punch	102
Jelly Soda	102

HOT CHOCOLATE MIXES

1. 4 cups milk powder
¾ cup cocoa
2 - 2 ½ cups sugar
dash salt
vanilla (optional)

Mix well and store in closed container.

To use: Add 3 tablespoons per cup and add water.

Kathy Johnston
Edmonton

2. 16 cups powdered milk
2 lbs Nestles Quik
1 cup icing sugar
6 oz Coffee Mate

Put all ingredients in a large pot and stir until well mixed. Bag into plastic bags; use as needed.
48 servings

To use: Take 1/3 cup of mix and fill with hot water. It is really good added to coffee for the adults.

Betty Evans
Edmonton

3. 16 cups skim milk powder
2 lbs hot chocolate mix
1 cup Coffee Mate
2 cups icing sugar

Mix together and store in ice cream pails in a dry area. This will keep indefinitely.

To use: Put 1/3 cup mix in your cup and add boiling water.

Julie Nielsen
Tamarac

4. 1 8-qt box powdered milk
1 16-oz box instant chocolate
6 oz Coffee Mate
2 cups powdered sugar

Mix together and store.

To use: 3 tablespoons per cup. Fill with hot water.



Margaret Campbell
Edmonton

HOT DRINKS

Friendship Tea I

2 cups Tang orange crystals
1 ½ cups sugar
½ cup instant tea
2 pkgs lemon Kool Aid
½ tsp cinnamon
½ tsp cloves

Mix together and store in dry container.

To use: Add about 2 tsp to 1 cup of boiling water.

Julie Nielsen
Tamarac

Friendship Tea II

1 cup instant tea
2 pkgs orange crystals
2 pkgs lemon crystals
2 tsp cloves
2 tsp cinnamon
1 cup sugar

Mix together.

To use: Add 2 tsp of mixture to cup and fill with boiling water.

Phyllis Clow
Edmonton

Mocha Drink

1 tsp instant coffee
1 tbsp hot chocolate mix
2 tsp sugar
boiling water

Put in mug, stir, and enjoy.

P.S. A dash of peppermint extract is good too.

Julie Nielsen
Tamarac

Mulled Apple Cider

1 48 oz can apple cider
½ pkg cinnamon candies

Heat in a large pot until warm. Serve in a mug with a cinnamon stick.

Phyllis Allen
Edmonton

Hot Drink Ideas

Just add water: Iced team with lemonade
Lemonade
Spiced apple drink (come as powder)
Orange crystals (Tang, Quench, etc.)

Phyllis Clow
Edmonton

HOT DRINKS

Cariboo (or spiced tea, which is red)

7 pkgs (17 g) powdered Hot Spiced Apple flavoured drink OR 1 120 g can
3 tbsp lemon Tang
½ tsp red Kool Aid (type that needs sugar added) OR raspberry, strawberry, etc.

Mix dry ingredients well.

To use: 1 tbsp of cariboo mix in a cup of hot water.

This is a nice hot drink after a day outside at the winter carnival. It is a bit on the sweet side and has cinnamon in it. Some people may not like it but I, for one, love it.

Susan Ruzek
Calgary

Skier's Tea

Tea bag
Lemon juice
Honey

Thermos
Bowl or glass measuring cup

Boil water, enough to fill thermos. Pour into mixing bowl. Add tea bag and make strong tea. Remove tea bag and add lemon until tea is almost colourless or a weak yellow-tan colour.

Now the tricky part! Add enough honey while stirring until the tea becomes cloudy. Pour tea into thermos and cap.

Go skiing and, when done, warm up with a cup of this tea while waiting for the last ones down to the car.

This drink, if done right, is just sweet enough and is a source of quick energy. Both young and old will appreciate a cup at the end of a perfect day of skiing.

Susan Ruzek
Calgary



COLD DRINKS

Apple-Orange Refresher

1 cup orange juice
1 cup apple juice
2 tsp lime juice

Yield: 4 ½ cup servings



Phyllis Allen
Edmonton

Pineapple Punch

2 cups unsweetened pineapple juice
2 6 oz cans frozen orange juice
1 large bottle gingerale
¼ cup lime juice
1 8 oz jar maraschino cherries
pineapple chunks

Combine all ingredients except gingerale. Refrigerate. Just before serving, add cold gingerale.

Makes 12 4-oz servings.

Julie Nielsen
Tamarac

Popsicle Punch

If, on a hot day, someone brings a couple of bags of popsicles to camp, put all leftover ones in a big pitcher and add apple juice. Serve.

Glen Allan District
Edmonton

Jelly Soda

Cooking Method: Stove top

Preparation time: 15 minutes

Servings: 6 - 8

Ingredients: 1 pkg (3 oz) jelly powder, any flavour
1 cup boiling water
½ cup cold water
1 28 oz bottle gingerale
1 pint vanilla ice cream

Dissolve jelly powder in boiling water; add cold water. Cool. Add gingerale gradually; stir to blend. Serve over ice cream in tall glasses. Nice on a hot day for a special treat.

Pat Ostapowich
Edmonton

LIGHT WEIGHT CAMPING FOODS

	Page
Trail Halvah	103
Mountain Mix	103
Gorp, Glop and Trail Mix	103
Gorp	104
Trail Mix Deluxe	104
Basic Ground Beef Mix	105
Icelandic Quick Bread	106
Hiking Lunch (Stuffed Apples)	106
Milk River Special	106
Noodle Casserole	107
The Only Way To Eat Oatmeal in the Morning	107
Soups	108
My Favourite One Potter	108
One-Pot Meal Ideas for Backpacking	109

MISCELLANEOUS

Rose Hip Jam	110
A Girl Guide's Delight	110

TRAIL HALVAH

This versatile food with a high carbohydrate content can be eaten as a snack or dessert. Made before camp, this is an excellent trail food for all ages.

Ingredients:

- 1 L (4 cups) sesame seeds
- 250ml (1 cup) cashews
- 250ml (1 cup) honey or molasses
- 250ml (1 cup) tahini (sesame paste)
- sesame seeds to cover

Grind sesame seeds and cashews in a seed grinder or blender. Pour the meal into a bowl and blend in tahini and sweetener with wooden spoon until halvah acquires the consistency of dough. Make small balls and roll them in same seeds. Wrap the balls in foil for longer storage time. Enjoy this ancient Roman trail food!

Margaret Seel
Calgary

MOUNTAIN MIX

Ingredients:

- 1 large package semi-sweet chocolate chips
- raisins
- almonds, unsalted, unblanched



Melt chocolate chips; add raisins and almonds to your own taste. If you like a lot of raisins and almonds add them, but make sure there is enough chocolate so that it will all hold together. Pour into a greased shallow pan as you would for fudge. When firm, cut into pieces.

This is good to take hiking or backpacking.

Eleanor Claydon
Edmonton

GORP, GLOP AND TRAIL MIX

A basic recipe:

- 1 part raisins
- 1 part salted peanuts
- 1 part Smarties
- ½ part sunflower seeds unsalted and shelled

Variations: Any part may be altered, e.g. use bridge mix instead of Smarties, change or add other types of nuts.

How can anything be so simple?

Margaret Campbell
Edmonton

GORP

Ingredients: 1 cup corn syrup, molasses or honey
 ¼ cup milk powder
 1 cup oatmeal
 ½ cup peanut butter
 ½ cup chocolate chips
 ½ cup wheat germ
 ½ cup or more crushed peanuts
 ½ cup raisins

Mix all together thoroughly. Roll into balls. Wrap each ball in waxed paper, twisting the ends. Chill.

Recipe Source: *Guide Handbook*

Kay Quon
Edmonton

TRAIL MIX DELUXE

Preparation method: Dehydration

Ingredients: Fruit - pineapple, banana, apples
 Lemon or pineapple juice
 1 container yogurt
 ½ cup honey

Cut fruit into thin rings or slices.

Method A Soak fruit in juice overnight (or at least 5 hours). Blot dry and place, so pieces do not touch drying shelves, on plastic wrap.

Method B Soak fruit overnight in mixture of yogurt and honey. Do not blot dry; just drip a little. Place on plastic wrap on shelf of dehydrator. Dry halfway, turn, put a little yogurt-honey mixture on top and finish drying.

Times: Pineapple: 10 - 16 hours, ready when pliable
 Bananas: 6 - 8 hours, ready when leathery
 Apples: 7 - 10 hours, ready when pliable

Mix fruit with nuts, raisins, chocolate chips, etc.

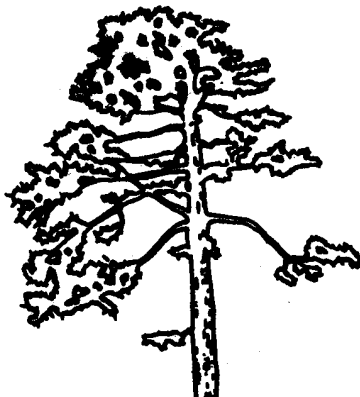

Lorna Smith
Parkland

BASIC GROUND BEEF MIX

At home preparation: Dehydration

Servings: 3 (recipe may be doubled, tripled, etc.)

Ingredients: 1 lb lean ground beef
garlic, if desired
½ cup finely chopped onion
pepper to taste
¼ tsp rosemary (optional)
1½ packets beef bouillon, or 1½ cubes, or 1½ tsp Bovril
¼ Worcestershire sauce
2 tbsp flour
1 tsp salt

Note: Like so many ground beef recipes, this one is infinitely variable. In other words, make a mixture you like and proceed.

Brown beef, onion, and garlic and *drain well*. Add the rest of the ingredients and cook over medium heat, scraping the flour off the bottom of the pan to brown evenly.

Spread the mixture thinly on a greased flat pan, and dry it in a 140° F oven, with the door propped open, for about 6 hours until crumbly.

After drying, spread on paper towels to absorb any extra grease. If grease is left on meat, it will turn rancid very quickly.

Store dried meat, labelled, in a plastic bag in the refrigerator, until ready to leave on trip. Plan to use within several days.

To reconstitute: Add 1-1/3 cups water, bring to a boil and simmer 5 minutes.

To use: Your imagination is the limit. Good in soups and one pot meals, on rice and noodles, etc., etc.

Margaret Campbell
Edmonton



ICELANDIC QUICK BREAD

Cooking method: One burner stove, buddy burner, wood coals

Servings: 5 hungry people

Ingredients: 1 L (4 cups) flour
10 ml (2 tsp) baking powder
5 ml (1 tsp) salt
2 eggs, beaten
• 500 ml (2 cups) sour cream or yogurt

Combine dry ingredients in a bowl. Add eggs and sour cream or yogurt to make workable dough. Lift the dough on a floured surface and knead gently. Roll into log. Cut into 2.5 cm (1" slices). Flatten each slice to ½ cm (¼") thickness before placing into a well greased pan, one or two at a time over high heat. Flip them once. Although the bread can be kept over several days, it can be eaten hot and fresh. Delicious for all meals!

Margaret Seel
Calgary

HIKING LUNCH (STUFFED APPLES)

Servings: 1 (make ahead or at camp)

Cut 1 large apple in half, lengthwise. Remove the core and a bit of pulp.

Mix peanut butter, coconut and raisins. Fill centre of apple with this mixture; place the halves together. Wrap securely.

Edna Dach
Edmonton

MILK RIVER SPECIAL

Cooking method: One burner stove

Cooking time: 5 minutes

Servings: per person

Ingredients: Cup of Noodles, flavour of choice
Magic Pantry Chicken a la King: ½ - 1 pkg depending on appetite
dehydrated carrots or zucchini

Prepare noodles, adding boiling water as directed and let stand. Dehydrated vegetables should be added to noodles. Heat Magic Pantry as directed. Serve Magic Pantry over noodles.

A great bad-weather meal!

Linda Campbell
Edmonton



NOODLE CASSEROLE

Cooking method: One burner stove

Servings: 2 very hungry or 3 regular appetites

Ingredients: 1 Ichiban chicken soup package
1 tbsp dried onion (optional)
1 package Surprise Peas
1 package foil packed tuna
1/3 cup skim milk powder
1/2 package white sauce mix
4 oz Swiss cheese

Cook peas as directed, add soup mix and onions for last three minutes. Drain water from pot and use 1 cup of liquid to make white sauce mix. Add milk powder and melt cheese into sauce. Drain tuna and put everything together. Warm if necessary.

Sue Burrows
Calgary

THE ONLY WAY TO EAT OATMEAL IN THE MORNING

Serving: 1

Ingredients: 1/2 pkg freeze-dried apples
raisins, nuts (optional)
1 pkg instant oatmeal
1 tbsp butter or margarine
cinnamon and sugar

Dehydrate apples; add raisins and/or nuts. Melt margarine; fry oatmeal in it. Put the two mixtures together; sprinkle sugar on top. If you prefer less sweet, add cinnamon only to oatmeal.

Sue Burrows
Calgary

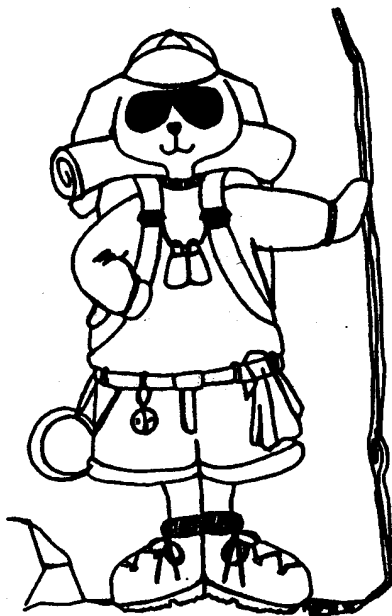

SOUPS

Putting together your own soup components results in delicious combinations not commercially available.

Start the soup by allowing about 500 ml or 2 cups of water per person. Add bouillon, chicken cubes or the "friendly four" flavour builders - parsley, onion, garlic, and celery leaves. Stir in spices, herbs and handfuls of other soup ingredients. Simmer several minutes until cooked. If desired, thicken the soup by adding dried potato flakes, flour, rice flour, or dried mix. Potato flakes will not lump when added to hot milk.

Soup ingredient combinations:

1. apples, onion, chicken, rice, curry
2. onions, carrots, cheddar cheese, flour to thicken
3. cucumber or green beans, sour cream, bacon, crumbled cheese
4. peanut butter, carrots, raisins, onions
5. tomatoes, onions, zucchini, mushrooms, basil, noodles (Chinese noodles cook faster)
6. broccoli, mushrooms, Swiss cheese, dill
7. dried sausage, dried potato slices, oregano, tomatoes
8. cheddar cheese, dried potato flakes, milk powder, paprika
9. clams, bacon, onion, parsley, dried potato slices, thyme

This can be cooked anywhere - from backpacking to residential camping.

Margaret Seel
Calgary

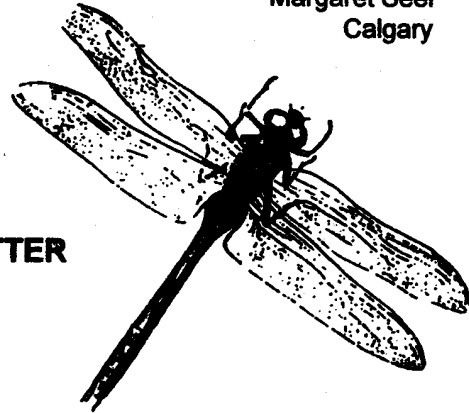

MY FAVOURITE ONE POTTER

Servings: 4 - 6 depending on appetite

Ingredients: 1 can Prem
1 packet Bachelor's dried peas
1 packet Idaho Scallop Potatoes

Get your billy can out for a really great gourmet treat! Bring 2½ cups water to a boil. Cut up Prem. Add scalloped potatoes (following package directions) and peas to water. Season with salt and pepper. Stir in Prem. Cook until potatoes and peas are tender, stirring constantly.

Variations: Add grated cheese. Use different canned meat such as flaked ham, turkey or chicken.
Add your favourite seasonings. Add a package of Cup-a-Soup.

Edna Dach
Edmonton

ONE POT MEAL IDEAS FOR BACKPACKING

Main ingredients (meats)

Any type of meat leftovers
from another meal

Canned meat (Prem is great)

Fish (canned or dried)

Jerky

Sausages

Summer sausage, salami, etc.

Meat substitutes, soyabean, etc.

Freeze dried meat

Bases (potato, grains, pasta)

Potatoes (dried type)
Instant, scalloped, mashed

Noodles and other pasta, any kind
Some of the instant varieties,
Chinese noodles, Kraft dinners,
Hamburger helpers, boxed mixes

Rice (all varieties) Rice-a-roni, make ahead
and add flavourings and pack in a ziplock
bag or seal-a-meal

Vegetables

Freeze dried or
dehydrated onions

Mushrooms
Veggie flakes

Some could be carried
in for the first meal like
carrots, potato, onion

Sauces

Cup of Soup (add water, gravy
mix, bouillon powder)

Packaged sauces (add powdered
milk)

Zest (those extras)

Pepper
Salt (seasoning, etc.)
Garlic
Curry
Parsley
Chives
Any spice

Top with croutons, cheese,
bacon bits, wheat germ, etc.

Edna Dach
Edmonton



ROSE HIP JAM

Cooking method: Stove top, open fire, buddy burners
Preparation time: 40 minutes
Cooking time: 20 minutes
Ingredients: 4 cups rosehips
2½ cups water
1 cup sugar
1 tsp lemon juice



Preserve rose hips the same day you pick them. Combine berries and water, and boil until berries are tender. Put through sieve to remove seeds. Combine 2 cups of the pulp, sugar, and lemon juice. Mix well. Bring slowly to a simmer and cook 20 minutes. Place in jar.

May be sealed with paraffin or eaten within a day or two.

Cooking method suitable for Pathfinders.

Recipe Source: Home Economics Division
Agricultural Extension Service
Alberta Department of Agriculture.

Dorothy-Ann Burgess
Chinook

A GIRL GUIDE'S DELIGHT

Ingredients: 2 cups love
2 cups kindness
1 tablespoon sweetness
1 pound money
7 drops tenderness
5 teaspoons helpfulness

*Mix love and kindness, and sift.
Beat sweetness and helpfulness until smooth.
Grease pan with 7 drops of tenderness.
Bake in 365° oven for 10 minutes.
Spread cake with patience.
Between layers spread a heart of old.
Yields the best Girl Guide leader in the world.*



N. J. Chambres
Montana

APPENDIX

	Page
A. Food Purchasing Guide for Quantity Service	111
B. Quantity Cooking	119
C. Resource List	129

APPENDIX A

ALBERTA AGRICULTURE HOMEDEX 1123

REPRODUCED WITH PERMISSION OF ALBERTA AGRICULTURE

FOOD PURCHASING GUIDE FOR QUANTITY SERVICE -- FOR 100 PEOPLE --

The following steps and product information can help simplify purchasing food for quantity service.

1. Plan menus and use recipes developed for quantity services (multiplying household recipes increases failure rate).
2. Prepare a complete grocery list. Then use food purchasing guide to estimate quantities required.
3. Enlist help of local merchants (dairies, bakeries, meat markets, grocery stores).
 - inquire if merchant can order special products or package sizes not normally sold
 - e.g. – a case of hamburger patties
 - a 2.84 L can of fruit or vegetables
 - discounts are usually given when case units are purchased
4. **PLAN EARLY**
This ensures special orders can be filled and allows opportunity to purchase sale items.

SAFETY FIRST

Proper handling and storage of food is important to reduce spoilage and decrease the possibility of food-borne illness.

1. Keep cold foods cold . . . 4°C (40°F) or lower and hot foods hot . . . 60°C (140°F) or higher.
2. Refrigerate food as soon as possible. Large quantities such as potatoes or meat should be placed in shallow pans so the entire amount will cool quickly.
3. Provide a place for handwashing. Food borne illnesses can result from unclean hands or utensils as well as from coughing or sneezing.
4. Arrange for sanitary dish washing. Rinse water must be 85°C (185°F) or a sanitizer will be required.

FOOD PURCHASING GUIDE FOR QUANTITY SERVICE

-- FOR 100 PEOPLE --

DAIRY PRODUCTS	APPROXIMATE SERVING SIZE	APPROXIMATE QUANTITY FOR PURCHASE	GENERAL INFORMATION
<p>Milk</p> <ul style="list-style-type: none"> - Fluid - Dry - Evaporated <p>Cream</p> <ul style="list-style-type: none"> - Light - Heavy <p>Ice Cream</p> <ul style="list-style-type: none"> - Bulk, 4 L pail or carton <p>Cheese</p> <ul style="list-style-type: none"> - Processed - Cheddar - Cottage <p>Eggs</p> <ul style="list-style-type: none"> - Fresh (medium size) 	<p>250 ml</p> <p>250 ml</p> <p>* 125 ml to 125 ml water</p> <p>30 ml</p> <p>25 ml, whipped</p> <p>75 ml scoop</p> <p>1.5 slices or 45 g</p> <p>45 g</p> <p>75 ml scoop</p> <p>1 egg</p>	<p>25 L</p> <p>2 pkg (500 g each)</p> <p>29 cans (435 ml each)</p> <p>3 L</p> <p>1.25 L unwhipped</p> <p>2 containers (4 L each)</p> <p>4.5 kg</p> <p>4.5 kg</p> <p>8 containers (1 kg each)</p> <p>100 eggs or 8.5 dozen</p>	<p>1000 ml = 1L</p> <p>1000 g - 1 kg</p> <p>1 L milk = 350 ml dry milk powder to 950 ml water</p> <p>1 L serves about 5</p> <p>0.5 kg = 1L grated</p> <p>0.5 kg = 500-560 ml</p> <p>1 case = 30 dozen</p> <p>FOR BAKING</p> <p>0.5 kg = 10 to 11 eggs</p> <p>250 ml = 4 to 5 whole</p> <p>OR 7 to 9 whites</p> <p>OR 12 to 14 yolks</p>
MEAT PRODUCTS	APPROXIMATE SERVING SIZE	APPROXIMATE QUANTITY FOR PURCHASE	GENERAL INFORMATION
<p>Beef</p> <ul style="list-style-type: none"> - Corned brisket - Ground - Roast, round (top or bottom, boneless) - Roast, rib - Roast, sirloin - Sausages, all beef - Steak, minute - Steak, sirloin (boneless strip) - Steak, swiss 	<p>60g</p> <p>90g</p> <p>60 g</p> <p>90 g</p> <p>60 g</p> <p>90 g</p> <p>60 g</p> <p>90 g</p> <p>120 g</p> <p>60 g</p> <p>90 g</p> <p>60 g</p> <p>90 g</p> <p>120 g</p> <p>180 g</p> <p>240 g</p> <p>360 g</p> <p>120 g</p>	<p>7.0 kg</p> <p>10.5 kg</p> <p>7.5 kg</p> <p>11.5 kg</p> <p>8.0 kg</p> <p>12.0 kg</p> <p>9.5 kg</p> <p>14.0 kg</p> <p>19.0 kg</p> <p>8.0 kg</p> <p>12.0 kg</p> <p>10.5 kg</p> <p>15.5 kg</p> <p>14.0 kg</p> <p>22.5 kg</p> <p>30.0 kg</p> <p>45.0 kg</p> <p>16.0 kg</p>	<p>WHEN PURCHASING ROASTS</p> <ol style="list-style-type: none"> 1. Select type as indicated in recipes. 2. Boned, rolled and tied roasts cut down on waste and slice easily. <p>30 g/sausage</p> <p>MINUTE/SWISS STEAKS</p> <ul style="list-style-type: none"> - are usually sold in 120 g portions when sold in bulk - smaller size portions can sometimes be obtained

MEAT PRODUCTS	APPROXIMATE SERVING SIZE	APPROXIMATE QUANTITY FOR PURCHASE	GENERAL INFORMATION
Pork			
Hams			
- Fresh, bone in	60 g 90 g	11.5 kg 17.0 kg	Suitable for frying, salads, etc.
- Precooked; round ('Tin-end')	60 g 90 g	6.0 kg 9.0 kg	
- Precooked; canned ('Pullman')	60 g 90 g	6.0 kg 9.0 kg	Suitable for sandwiches or cold plates
- Roast, loin	60 g 90 g	8.5 kg 11.5 kg	"centre-cut" ensures chops are about 120 g each 30 g/sausage
- Chops, "centre-cut"	1 chop 2 chops	14.0 kg 28.0 kg	
- Sausages, all pork	60 g 90 g	10.5 kg 15.5 kg	18-20 slices/500 g
- Bacon	3 slices	8.5 kg	
- Spareribs	120 g 180 g	13.0 kg 17.5 kg	

MEAT PRODUCTS	APPROXIMATE SERVING SIZE	APPROXIMATE QUANTITY FOR PURCHASE	GENERAL INFORMATION
Veal			
- Cutlets, 120 g	1 cutlet 2 cutlets	14.0 kg 28.0 kg	Choplets are a cheaper version of cutlets
- Roasts, leg	60 g 90 g	11.5 kg 17.0 kg	
- Stew (cubed)	60 g	7.5 kg	
Lamb			
- Chops, 120 g	1 chop 2 chops	15.0 kg 30.0 kg	
- Roast, leg or loin (bone-in)	60 g 90 g	14.0 kg 21.0 kg	
- Stew (cubed)	60 g	7.5 kg	

POULTRY & FISH PRODUCTS	APPROXIMATE SERVING SIZE	APPROXIMATE QUANTITY FOR PURCHASE	GENERAL INFORMATION
Poultry			
Chicken, Fried	2 pieces	34.0 kg	Turkey roasts & rolls come raw or precooked in light, dark or light-dark meat combinations
Turkey, fresh	60 g 90 g	16.5 kg 25.0 kg	
Turkey, roast or roll			
- cooked	60 g 90 g	6.5 kg 9.6 kg	
- uncooked	60 g 90 g	8.5 kg 12.5 kg	

POULTRY & FISH PRODUCTS	APPROXIMATE SERVING SIZE	APPROXIMATE QUANTITY FOR PURCHASE	GENERAL INFORMATION
Fish Fillets, fresh or frozen Portions - Breaded or unbreaded Sticks Canned - Salmon or Tuna	60 g 60 g 2 sticks 90 g	10.0 kg 12.0 kg 6.0 kg 28 to 30 cans (220 g each)	30 g/stick
VARIETY MEATS & ALTERNATES	APPROXIMATE SERVING SIZE	APPROXIMATE QUANTITY FOR PURCHASE	GENERAL INFORMATION
Liver, beef Luncheon meats Frankfurters (Hot dogs) Baked Beans Hamburger Patties	90 g 30 g 60 g 1 frank 1 frank 125 ml 1 pattie (120 g)	15.0 kg 3.0 kg 6.0 kg 3.0 kg 4.5 kg 12.5 kg 100 patties OR 12.0 kg	average portion size = 120 g when precut 30 g/slice 16 franks/500 g 10 franks/500 g - hamburger patties are available in various weights - beef-soy burgers have less shrinkage - there are about 45 to 50 patties (120 g each) per 5 kg box
CEREAL PRODUCTS	APPROXIMATE SERVING SIZE	APPROXIMATE QUANTITY FOR PURCHASE	GENERAL INFORMATION
Bread (450 g) Cereal - Dry; flakes - Cooked Crackers - Single crackers Macaroni Noodles Rice	1 slice 175 ml 125 ml 4 single crackers 125 ml (cooked) 125 ml (cooked) 125 ml (cooked)	7 loaves 1.5 kg 2.5 kg (raw) 1.1 kg 3.0 kg 3.0 kg 1.5 kg	16 slices/loaf

VEGETABLES	APPROXIMATE SERVING SIZE	APPROXIMATE QUANTITY FOR PURCHASE	GENERAL INFORMATION
Cauliflower - Frozen	125 ml	10 pkg (907 g pkg)	
Celery - Fresh	2 sticks (8 cm long)	2 to 3 kg	
Corn - Cob - Frozen, whole kernel - Canned, whole kernel	1 ear 125 ml 12.5 ml	100 ears 10 pkg (907 g each) 30 cans (398 ml each) OR 4 CANS (2.84 L each)	
Onions, chopped	15 ml	1 to 1.5 kg	
Peas - Frozen - Canned	125 ml 125 ml	9 pkg (907 g each) 30 cans (398 ml each) OR 4 cans (2.84 ml each)	
Potatoes - Baked or Boiled - Mashed - Instant - French Fries (side-order)	1 medium 75 ml scoop 75 ml (reconstituted) 10 pieces (5x1x1 cm)	11 to 11.5 kg 13 to 13.5 kg 1. 15 to 2 kg 13 pkg (907 g each)	"Baker" potatoes are good for baking because of uniform size
Salad - Shredded lettuce (garnish)	60 ml	4 heads	1 to 1.25 kg/medium head
Tossed Salad - Lettuce - Celery - Green peppers - Green onions - Firm tomatoes (opt) - Dressing	250 ml	10 heads 4 heads 5 6 bunches 2 kg 2 L	
Tomatoes, fresh	2 slices	2.5 to 3 kg	
Turnip - Fresh, cubed - Frozen, cubed	125 ml 125 ml	13 to 14 kg 8 pkg (907 g each)	<u>Raw Vegetable Tray</u> Because of large amount of waste involved, allow 170 to 250 g raw unprepared vegetables for each individual serving
Raw Vegetable Tray - Fresh, assorted	120 to 160 g	17 to 25 kg	
MISCELLANEOUS	APPROXIMATE SERVING SIZE	APPROXIMATE QUANTITY FOR PURCHASE	GENERAL INFORMATION
Butter/Margarine - Print - Pats	10 ml 2 pats	3 prints 200 pats	1 print = 454 g pats may be sold through local dairies in 2.5 kg orders
Salad Dressing/Mayonnaise	15 ml	2 L	70-75 pats/500 g
Ketchup	5 to 10 ml	1 L	

MISCELLANEOUS	APPROXIMATE SERVING SIZE	APPROXIMATE QUANTITY FOR PURCHASE	GENERAL INFORMATION
Mustard	5 to 10 ml	1 L	
Peanut Butter	30 ml	2 kg	
Jams, Jellies	15 ml	1 kg	
Syrups	30 ml	3.25 L	
Sugar			
- Granulated	5 ml	500 g	
- Cubes	1 cube	1 pkg (500 g)	144 cubes/pkg
Coffee			
- Regular grind	250 ml	1 kg	
- Instant	250 ml	150 g	
Tea	250 ml	250 g	

KITCHEN METRICS	HELPFUL HINTS
------------------------	----------------------

VOLUME

Use metric measures for metric recipes. Measures are marked in millilitres (ml) and are available in the following sizes:

1000 ml = 1L	250 ml	25 ml
500 ml	125 ml	15 ml
250 ml	50 ml	5 ml
		2 ml
		1 ml

TEMPERATURE

Most commonly used oven temperatures.

$^{\circ}\text{C}$ replaces $^{\circ}\text{F}$	$^{\circ}\text{C}$ replaces $^{\circ}\text{F}$
100 200	190 375
150 300	200 400
160 325	220 425
180 350	230 450

Refrigerator temperature: 4°C replaces 40°F
Freezer temperature: -18°C replaces 0°F

MASS

1 kg (1000 g) is slightly more than 2 pounds
30 g is about 1 ounce

LENGTH

1 cm (10 mm) is slightly less than $\frac{1}{2}$ inch
5 cm is about 2 inches

If a recipe calls for a

- No. 300 can or 14 fl oz buy 398 ml
- No. 303 can or 16 fl oz buy 500 ml
- No. 2 can or 19 fl oz buy 540 ml
- No. 2 $\frac{1}{2}$ can or 29 fl oz buy 875 ml
- No. 10 can or 100 fl oz buy 3 L

-
- 4 oz can is about 113 to 125 g
 - 6 fl oz can is about 237 ml
 - 10 fl oz can is about 284 ml
 - 12 fl oz can is about 341 ml
-

- 75 ml scoop is a No. 12 Dipper (1/3 cup)
- 125 ml scoop is a No. 18 Dipper (1/2 cup)
- 50 ml scoop is a No. 16 Dipper (1/4 cup)

APPENDIX B

QUANTITY COOKING

REPRODUCED BY PERMISSION FROM THE BLUE FLAME KITCHEN
NORTHWESTERN UTILITIES.

General Tips for Serving a Crowd

- Saucy foods should not be served on paper plates.
- If people will not be sitting at tables, do not serve food which requires a knife.
- Rent or borrow equipment such as plates, utensils, folding chairs, glasses and serving pieces.
- Check prices of the items at a catering service; it may be cheaper than making your own.
- Use disposables when possible.
- All of the recipes and quantities suggested are based on a mixed group with average appetites. If the group consists mainly of teenagers or the meal is planned for after heavy activity (ie. camping or hiking), increase the quantities.
- Unless otherwise indicated, recipes are based on serving 100 people.

MISCELLANEOUS INFORMATION FOR PICNICS AND PARTIES

- Wieners and buns may be purchased by number. Hamburger patties may be purchased (frozen) from frozen food outlets.
- For barbecue parties:
 - Pretzels - 15 people per box
 - Potato chips - 10 200 g boxes
 - Pickles - 5 909 ml jars
 - Mustard - ½ ounce (15 ml) per person
 - Relish - ½ ounce (15 ml) per person
 - Ketchup - ½ ounce (15 ml) per person

Beverages

- For a large group, have a choice of at least 2 beverages.
- Allow more coffee for breakfast or brunch.
- Cold beverages must be kept very cold.
- For meals, allow 2 servings of beverage.
- Cream - 1 ounce (30 ml) per person – 3 litres.
- Sugar - 2 pounds (1 kg).

COFFEE

- The easiest way to make a large volume of coffee is to use a large urn. These are available at rental agencies or often can be borrowed. For the best flavor, start with cold water and remove grounds when the coffee has perked.
- One pound (454 g) ground coffee = 100 cups
- It is a good idea to have some instant coffee on hand for those who like stronger coffee.

TEA

The best tea is made one pot at a time. Tea essence can be used when a lot has to be prepared at the last minute.

TEA ESSENCE

2 ½ cups (625 ml) tea leaves
(1 lb = 5 cups)

10 cups (2.5 L) boiling water

Pour boiling water over tea and let stand 10 minutes. Drain off the concentrated tea. This essence can be made a few hours in advance. To make tea, place ½ cup essence in an 8-cup tea pot and fill with boiling water. Serve at once.

COCOA

If you prefer to use instant cocoa, there are two types to choose from. The cocoa that is added to milk is cheaper, but you must consider the cost of the milk. The variety that is added to hot water is the most convenient and there is no concern about scorching.

QUANTITY COCOA

6 cups (1.5 L) sugar (3 lbs)
4 cups (1 L) cocoa (1 lb)

1 tsp (5 ml) salt
8 cups (2 L) water

4 gallons (20 L) hot milk
2 tsp (10 ml) vanilla

Mix together sugar, cocoa and salt. Add the water and stir until smooth. Heat to boiling point and boil 3 minutes. Then add 4 gallons hot milk. Add vanilla just before serving.

<u>BRAND NAME</u>	<u>SIZE</u>	<u>NUMBER OF TEASPOONS</u>	<u>NUMBER OF SERVINGS</u>	<u>METRIC VOLUME</u>	<u>VOLUME</u>
Taster's Choice; freeze-dried	2 oz - 57 g	50 teaspoons	50	1 1/8 cup	250 ml
Maxwell House; instant	2 oz - 57 g	40 teaspoons	40	7/8 cup	200 ml
Coffee-mate	3 oz - 85 g	20 heaping teaspoons	20	7/8 cup	200 ml
Fry's Cocoa	½ lb - 227 g	50 heaping teaspoons	50	2 cups	500 ml
Nestle's Quik	1 lb - 454 g	125 heaping teaspoons	42	4 cups	1 L
Supreme Chocolate		100 heaping teaspoons	50		
Nestle's Instant Hot Chocolate	1 lb - 454 g	36 heaping teaspoons	18	4 cups	1 L
Carnation Instant Hot Chocolate	25 oz - 709 g	124 heaping teaspoons	31	5 cups	1.25 L
Hershey's Chocolate Syrup	12 oz - 341 g		20		

SOFT DRINKS

Allow 3 284 ml bottles per person. Keep the selection down to 3 or 4. Young children prefer fruit flavours while teenagers and adults generally prefer Coke, Seven-up and Orange.

Teenagers

Coke - 33%
Seven-up - 33%
Orange - 33%

Adults

Coke - 55%
Seven-up and Gingerale
Orange
- allow some soda water

PUNCH

Allow: 12 oz (375 ml) per person
4 oz (125 ml) per person

FROSTY FRUIT PUNCH

2 1.36 L cans unsweetened pineapple juice 1 1/3 cups (350 ml) lemon juice, fresh, frozen or canned 2 cups (500 ml) sugar

2 2/3 cups (700 ml) orange juice, fresh, frozen or canned 2/3 cup (175 ml) lime juice, fresh, frozen or canned

2 750 ml bottles gingerale, chilled 2 750 ml bottles club soda, chilled

Combine fruit juices and sugar; chill thoroughly. Pour over a large cake of ice in a punch bowl. Pour gingerale and club soda slowly down the sides of the bowl. For trim, float a twist of sliced orange and sprigs of fresh mint on the block of ice. Makes 60 4-oz servings. Serves 20.

CITRUS SUNSHINE PUNCH

1 355 ml can frozen orange juice concentrate 1 355 ml can frozen limeade concentrate 2 750 ml bottles gingerale, chilled

1 355 ml can frozen lemonade concentrate 8 cups (2 L) cold water

Combine all ingredients except gingerale. Pour over an ice block in a bowl. Add gingerale just before serving. Garnish with mint leaves. Makes 50 4-oz servings. Serves 15.

Breakfast

- Avoid toast if possible; sweet rolls are easier.
- French toast keeps better than pancakes.
- Pancake mixes that only require water are very handy; try them first for quality.
- Allow more milk and juice if breakfast is for young people.

<u>FOOD</u>	<u>AMOUNT PER PERSON</u>	<u>AMOUNT FOR 100</u>	
		<u>IMPERIAL MEASURE</u>	<u>METRIC MEASURE</u>
Sausage	2 links	18 pounds	8 kg
Bacon	3 slices	17 pounds	8 kg
Hash Browns	3 oz	19 pounds	9 kg
Eggs	2	17 dozen	
Sweet Rolls	1 1/2	13 dozen	
Juice	4 oz	9 48-oz cans	9 1.36 L cans
Mix - mixed ages	2 oz		6 L
- young people	8 oz		30 L
Fresh fruit	1 *		
Syrup	2 oz	5 32 oz bottles	5 L
Butter	1 tbsp or 2 patties	3 lbs	
Whipped Butter		2 lbs	
Pancakes	3		
Aunt Jemima Complete Mix	1 kg box - 50 - 60 4" (10 cm) pancakes		6 - 7 boxes
Snackery Buttermilk Pancake Mix	1 kg box - 50 - 60 4" (10 cm) pancakes		6 - 7 bags

Heat, but do not boil, the milk and broth. Melt the butter in a large Dutch oven over medium heat. Saute onion, celery and garlic (if using fresh mushrooms, saute with onion, celery and garlic). Add flour and slowly stir in hot liquid. Stir constantly to avoid scorching. Put meat and green pepper into roasting pans (if using canned mushrooms, add at this point). Add Worcestershire sauce and sherry to sauce; taste and adjust seasoning. Pour sauce over meat. Heat in 350°F (180° F) oven until bubbling, about 1½ hours. Serve in patty shells or on hot biscuits.

BEEF STEW

25 lbs (12 kg) stewing beef, cubed	Beef stock	6 lbs (3 kg) carrots, diced
6 tbsp (75 ml) paprika	4 tbsp (50 ml) salt	6 lbs (3 kg) potatoes, diced (optional)
4 lbs (2 kg) onions, chopped	1 tbsp (15 ml) pepper	1 bunch celery, chopped
2 - 3 cloves garlic	4 bay leaves	2 2-lb bags (2 kg) peas
2 796 ml cans tomatoes	1 tbsp (15 ml) thyme	
3 - 4 cups (1 L approx.) flour	3 tbsp (45 ml) Worcestershire	

Sprinkle the beef with paprika and brown in a 450°F (230°C) oven. Add onions, tomatoes and seasoning. Cook in a 350°F (180°C) oven for about 2½ hours. Add the remaining vegetables and cook about 45 minutes or until tender. Mix the flour with water and add to the broth. Cook until the broth thickens. Taste and add salt and pepper if necessary.

BAKED SPAGHETTI

17 lbs (8 kg) lean ground beef	4 cloves garlic, crushed	½ cup (125 ml) salt
5 796 ml cans whole tomatoes	4 green pepper	¼ cup (50 ml) pepper
3 369 ml cans tomato paste	½ cup (125 ml) oregano	¼ cup (50 ml) Worcestershire sauce
1 head celery, chopped	¼ cup (50 ml) chili powder	2 bay leaves
8 onions, chopped	¼ cup (50 ml) sweet basil	15 - 18 lbs (7 - 8 kg) Spaghetti

Brown the meat in a roasting pan in a 450°F (230°C) oven. Drain. Add remaining ingredients, except spaghetti. Bake at 350°F (180°C) oven for 2½ to 3 hours in a covered pan. Check occasionally adding tomato juice if more liquid is required. Taste and adjust seasonings. In a larger canner, bring about 50 cups (13 L) of salted water to a boil. Add about ½ of the spaghetti, stirring constantly until the water returns to a boil. Cook until tender. Repeat with remaining spaghetti. Drain, rinse and mix spaghetti with ½ cup of oil and 1 cup of melted butter. Stir into spaghetti sauce and serve.

BAKED BEANS

16 lbs (8 kg) dried beans	8 whole onions	½ cup (125 ml) dry mustard
5 lbs (2.5 kg) salt pork, cubed	½ cup (125 ml) salt	Molasses
	2 cups (500 ml) brown sugar	10 cups (2.5 L) water

Place beans in a large pot and add cold water until it comes to about 2 inches (5 cm) above the beans. Soak overnight. Drain and cover with fresh water. Bring to a boil and simmer for 2½ hours. Add water if necessary during the cooking time. Drain. Put beans, pork, and onions in a casserole dish. Combine the rest of the ingredients; pour over the beans. Bake, covered at 300°F (150°C) for about 8 hours or until tender. Remove onions and serve.

- To add interest to canned baked beans, try adding any one or a combination of the following:
 - prepared mustard
 - ketchup
 - cubes of ham
 - pineapple chunks
 - Worcestershire sauce
- Allow 8 ounces (250 ml) of beans per person.

Vegetables

POTATOES

- When preparing potatoes for a large group, consider using dehydrated or frozen.
- The flavour of instant mashed potatoes is very good if milk and butter or margarine have been added. Allow them to stand covered in a warm oven for ½ hour before serving.
- Dehydrated scalloped potatoes have fairly good flavour.
- If you have the proper facilities for deep frying, french fries are quick, however they must be served immediately.
- Frozen hash browns are an economical way to make breakfast more filling. Saute some onions before adding the potatoes.
- Baked potatoes must be of uniform size to be ready at the same time.

Mashed:	4 ounces (125 g) per person; 25 lbs (12 kg) peeled
Baked:	1 per person
French Fries:	3 ounces (100 g) per person; 19 (10 kg)
Sour Cream:	2 ounces (73 g) per person; 6.5 L

SCALLOPED POTATOES

40 cups (10 L) milk	6 onions, chopped	½ cup (125 ml) salt
1 lb (454 g) butter or margarine	3 cups (750 ml) flour	1/8 tsp Tabasco
25 lbs (12 kg) peeled potatoes, sliced		

Heat milk, but do not boil. Heat margarine in a large pan. Saute onions. Add flour, salt and Tabasco. Slowly stir in hot milk. Bring to a boil, stirring constantly. This sauce will be quite thin. Taste and adjust seasonings. Put potatoes in a shallow (3-inch) roasting pan; cover with sauce and stir well. Cover and bake at 350° F (180°C) for 2 hours or until nearly tender. Sprinkle with paprika. Bake for an additional ½ hour uncovered.

OTHER VEGETABLES

- Frozen vegetables eliminate preparation.
- Bring a large pot about 1/3 full of water to a boil. Slowly stir in vegetables. Return to a boil. Drain and serve immediately.
- Vegetables that are not suitable for a large group include brussel sprouts, cabbage, spinach and lima beans.
- Vegetables that require special care, so as not to overcook them, include broccoli, cauliflower, peas, and green beans.
- Vegetables that tolerate mishandling are carrots and corn.
- Use vegetables as a colourful accent to your meal.
- 4 ounces (125 g) per person if only 1 vegetable.
- 2 ½ ounces (85 g) of each vegetable per person if 2 or more vegetables or a large selection of foods are being served.

Salads

- For a hot meal, allow 1 or 2 types of salad.
- For a cold buffet, up to 6 salads can be served; judge by the variety of foods offered.
- Jellied salads should be avoided with hot meals and on very hot days.
- To crisp vegetables for salads, wash thoroughly with cold water, drain, wrap in paper towels and plastic bags, and keep in the crisper drawer.
- Allow 4 ounces (125 g) if only one salad is served; 1½ ounces (40 g) if several are available.

THREE BEAN SALAD

5 398 ml cans garbanzo beans	3 cups (750 ml) medium onions, sliced	2½ cups (625 ml) salad oil
5 398 ml cans kidney beans		5 cups (1.25 L) vinegar
5 398 ml cans green beans	5 medium green peppers, chopped	2 tbsp (30 ml) salt
5 398 ml yellow wax beans		1 tbsp (15 ml) pepper
		3 cups (750 ml) sugar

Mix the last 5 ingredients and pour over the vegetables. Refrigerate overnight. Drain before serving. Keeps well for 4 to 6 days if refrigerated.

POTATO SALAD

2 cups (500 ml) salad oil	¼ cup (50 ml) salt	1 head celery, chopped
1 cup (250 ml) vinegar	2 tbsp (25 ml) freshly ground pepper	3 cups (750 ml) radishes, sliced
2 cups (500 ml) green onions, chopped	Dash hot red pepper sauce	24 hard cooked eggs
1 tbsp (15 ml) dry mustard	25 lbs (12 kg) potatoes	8 cups (2 L) mayonnaise or salad dressing

Combine the first 7 ingredients. Cook the potatoes and cube while still hot. Pour the oil and vinegar dressing over. Chill for at least 2 hours, tossing occasionally. Add remaining ingredients and toss and chill. This mixture should not be held longer than 6 hours.

CARROT AND RAISIN SALAD

2 lbs (1 kg) raisins	3 tbsp (45 ml) sugar	16 lbs (7.5 kg) carrots
6 cups (1.5 L) water	1 tsp (5 ml) salt	6 cups (1.5 L) mayonnaise or salad dressing
1/3 cup (75 ml) lemon juice		

Combine the raisins, water, sugar, salt, and lemon juice and bring to a boil. Remove from heat and let stand about 15 minutes. Drain and cool raisins. Mix raisins, carrots and mayonnaise. Makes 100 4-oz servings.

FOURTEEN DAY COLESLAW

10 heads cabbage, shredded	5 cups (1.250 L) sugar	3 tbsp (45 ml) salt
3 lbs (1.5 kg) carrots, shredded	7½ cups (1.875 L) vinegar	2 tbsp (30 ml) celery seed
10 spanish onions, shredded	2½ cups (625 ml) water	3 tbsp (45 ml) mustard seed

Toss the shredded vegetables together. Combine the remaining ingredients and bring to a boil. Simmer 3 minutes. Chill until cold. Pour over the vegetables. Cover. Marinate for at least 24 hours. Will keep 2 weeks.

COLESLAW

10 heads cabbage, shredded	Dressing:	
3 bunches green onions, chopped	2½ cups (625 ml) mayonnaise	2 tbsp (25 ml) salt
10 green peppers, chopped	2½ cups (625 ml) sour cream	1 1/3 cups (325 ml) vinegar

Combine ingredients for the dressing and set aside. Combine vegetables and add dressing; toss lightly. Chill well and serve.

TOSSED GREEN SALAD

10 heads lettuce (may use a variety of lettuces)	2 cups (500 ml) radishes, sliced	10 green peppers, chopped
6 bunches green onions, chopped	2 bunches celery, chopped	5 lbs (2.5 kg) firm tomatoes, optional

Toss and serve with a variety of dressings.

JELLIED PERFECTION SALAD

8 envelopes gelatin	2 cups (500 ml) mild vinegar or lemon juice	8 green peppers, finely chopped
2 cups (500 ml) cold water		8 pimentos, finely chopped (optional)
20 cups (5 L) boiling water	4 tsp (20 ml) salt	4 cups (1 L) carrots, finely shredded
	2 qts (2 L) cabbage, finely shredded	1 tsp (5 ml) pepper

Soak gelatin in cold water. Add to boiling water; stir until dissolved. Add vinegar, salt and pepper. Set aside until partially thickened. Add mixed, chopped vegetables. Turn into molds and chill. Unmold on lettuce and serve with mayonnaise.

GOLDEN GLOW SALAD

10 pkgs (85 g) lemon jelly powder	5/8 cup (125 ml) vinegar	10 cups (2.5 L) diced pineapple
	10 cups (2.5 L) pineapple juice	10 cups (2.5 L) grated raw carrots
10 cups (2.5 L) hot water	5 tsp (25 ml) salt	3 cups (750 ml) chopped nuts

Dissolve jelly powder in hot water. Stir well. Add pineapple juice and seasonings. Chill until slightly thickened; fold in remaining ingredients. Pour into molds and chill until firm. Unmold on lettuce; garnish with ripe olives and mayonnaise.

MACARONI AND HAM SALAD

6 lbs (3 kg) macaroni	3 green peppers, chopped	1½ tsp (7 ml) pepper
3 lbs (1.5 kg) ham, julienned	1½ cups (375 ml) onion, chopped	3 cups (750 ml) oil
3 lbs (1.5 kg) celery, chopped	1 cup (250 ml) cider vinegar	2 tbsp (30 ml) sugar
3 128 ml jars pimento	1 tbsp (15 ml) salt	4 cups (1 L) salad dressing

Combine the first 6 ingredients. Combine vinegar, salt, pepper, oil, and sugar and beat well. Pour over the first mixture; toss. Add enough salad dressing to coat. Chill and serve.

Sandwiches

- Arrange as many slices of bread in pairs as the counter will hold.
- Have the butter or margarine at room temperature.
- Whip the butter or margarine and spread with a wide bladed spatula.
- Use a small ice cream scoop to measure filling onto bread.
- Cut sandwiches and arrange on platter.
- Cover with a lightly dampened clean cloth and wrap in plastic.
- Sandwich fillings do not keep well and should be made the same day.
- For variety, use the fillings in crusty buns.
- Average 20 ounce loaf - 20 slices of bread

1 pound butter or margarine - 100 slices

1 slice (1 ounce or 30 grams) luncheon meat per sandwich

1 to 1 1/3 ounces mixed filling per sandwich

2 slices per person for afternoon tea

4 slices per person for a picnic

CHICKEN SALAD SANDWICH

8 cups (2 L) chicken, finely
chopped

1 1/2 cups (375 ml) celery,
finely chopped

1 cup (250 ml) sweet pickles,
finely chopped

3 tbsp (45 ml) prepared mustard

3 cups (750 ml) salad dressing

1 1/2 tbsp (20 ml) lemon juice

2 tsp (10 ml) salt

Combine all ingredients and mix thoroughly. Makes 50 to 70 sandwiches.

NOTE: Ham or luncheon meat may be substituted for chicken.

EGG SALAD SANDWICH

40 hard cooked eggs

2 1/2 cups (625 ml) mayonnaise or
salad dressing

2 tbsp (25 ml) prepared mustard

1/2 cup (125 ml) chives or
green onion, chopped

Salt and pepper to taste

Chop eggs finely. Combine all ingredients. Makes 50 sandwiches.

Desserts

Simple desserts are best. One favorite is ice cream. The volume you need will depend on the size of scoop used.

1 Litre - 1/2 cup (125 ml) servings - 8 servings

1/3 cup (75 ml) servings - 12 servings

For 100 people - 9 - 12 litres

Squares - allow 2 1/2 servings per person

RESOURCE LIST

APPENDIX C

Roughing It Easy I + II,
Dian Thomas,
Warner Books, 1977

Hungry Hiker's Book of Good Cooking,
Gretchen McHugh, Alfred A. Knopf, 1982

The Little Cook Book for the Great Outdoors,
Linda Darling and Suat Fuzlak,
Rocky Mountain Books, 1981

The One Burner Gourmet,
Harriett Barker,
Contemporary Sports Books, 1975

Supermarket Backpacker,
Harriett Barker
Contemporary Books, Inc. 1977

The New Healthy Trail Food Book,
Dorcas S. Miller,
Eastwoods Press, 1980

The Well - Fed Backpacker,
June Fleming,
Vintage Books, 1981

Trailside Cooking,
Russ Mohny,
Stackpole Books, 1976